



FCC RF Test Report

APPLICANT : Magne AI Global tech limited
EQUIPMENT : MAG1
BRAND NAME : MaQ
MODEL NAME : MA1
FCC ID : 2BVCPGC603606
STANDARD : 47 CFR Part 27 Subpart O (3700-3980MHz)
CLASSIFICATION : PCS Licensed Transmitter Held to Ear (PCE)
TEST DATE(S) : Mar. 05, 2026 ~ Mar 15, 2026

We, Sporton International Inc. (KunShan), would like to declare that the tested sample has been evaluated in accordance with the procedures given in ANSI C63.26-2015 and shown compliance with the applicable technical standards.

The test results in this report apply exclusively to the tested model / sample. Without written approval of Sporton International Inc. (KunShan), the test report shall not be reproduced except in full.

Jason Jia

Approved by: Jason Jia



Sporton International Inc. (Kunshan)

**No. 1098, Pengxi North Road, Kunshan Economic Development Zone Jiangsu Province 215300
People's Republic of China**



TABLE OF CONTENTS

REVISION HISTORY...3
SUMMARY OF TEST RESULT...4
1 GENERAL DESCRIPTION...5
1.1 Applicant...5
1.2 Manufacturer...5
1.3 Product Feature of Equipment Under Test...5
1.4 Product Specification of Equipment Under Test...5
1.5 Modification of EUT...6
1.6 Maximum EIRP and Emission Designator...6
1.7 Testing Location...7
1.8 Test Software...8
1.9 Applicable Standards...8
2 TEST CONFIGURATION OF EQUIPMENT UNDER TEST...9
2.1 Test Mode...9
2.2 Connection Diagram of Test System...10
2.3 Support Unit used in test configuration and system...10
2.4 Measurement Results Explanation Example...10
2.5 Frequency List of Low/Middle/High Channels...11
3 CONDUCTED TEST ITEMS...13
3.1 Measuring Instruments...13
3.2 Test Setup...13
3.3 Test Result of Conducted Test...13
3.4 Conducted Output Power and EIRP...14
3.5 Peak-to-Average Ratio...15
3.6 Occupied Bandwidth...16
3.7 Conducted Band Edge...17
3.8 Conducted Spurious Emission...18
3.9 Frequency Stability...19
4 RADIATED TEST ITEMS...20
4.1 Measuring Instruments...20
4.2 Test Setup...20
4.3 Test Result of Radiated Test...21
4.4 Radiated Spurious Emission...22
5 LIST OF MEASURING EQUIPMENT...23
6 MEASUREMENT UNCERTAINTY...24
APPENDIX A. TEST RESULTS OF CONDUCTED TEST
APPENDIX B. TEST RESULTS OF RADIATED TEST
APPENDIX C. TEST SETUP PHOTOGRAPHS



SUMMARY OF TEST RESULT

Report Section	FCC Rule	Description	Limit	Result	Remark
3.4	§2.1046	Conducted Output Power	Reporting Only	PASS	-
	§27.50(j)(3)	Equivalent Isotropic Radiated Power (5G NR n77, n78)	EIRP < 1Watt		
3.5	§27.50(j)(4)	Peak-to-Average Ratio	<13 dB	PASS	-
3.6	§2.1049	Occupied Bandwidth	Reporting Only	PASS	-
3.7	§2.1051	Conducted Band Edge Measurement (5G NR n77, n78)	< 43+10log10(P[Watts])	PASS	-
	§27.53(l)(2)				
3.8	§2.1051	Conducted Spurious Emission (5G NR n77, n78)	< 43+10log10(P[Watts])	PASS	-
	§27.53(l)(2)				
3.9	§27.54	Frequency Stability Temperature & Voltage	Within Authorized Band	PASS	-
4.4	§2.1053 §27.53(l)(2)	Radiated Spurious Emission (5G NR n77, n78)	< 43+10log ₁₀ (P[Watts])	PASS	Under limit 23.15 dB at 7404.00 MHz

Conformity Assessment Condition:

- The test results (PASS/FAIL) with all measurement uncertainty excluded are presented against the regulation limits or in accordance with the requirements stipulated by the applicant/manufacturer who shall bear all the risks of non-compliance that may potentially occur if measurement uncertainty is taken into account.
- The measurement uncertainty please refer to each test result in the section "Measurement Uncertainty"

Disclaimer:

The product specifications of the EUT presented in the test report that may affect the test assessments are declared by the manufacturer who shall take full responsibility for the authenticity.



1 General Description

1.1 Applicant

Magne AI Global tech limited

FLAT 1019B,10/F,LIVEN HOUSE,NO.61-63 KING YIP STREET KWUN TONG HK

1.2 Manufacturer

FIH Precision Electronics(Lang Fang)Co.,Ltd.

No. 18 Furao Road, Longhe High tech Industrial Development Zone, Anci District, Langfang City, Hebei Province

1.3 Product Feature of Equipment Under Test

Product Feature	
Equipment	MAG1
Brand Name	MaQ
Model Name	MA1
FCC ID	2BVCPGC603606
IMEI Code	Conducted : 016813000000057/016813000000065 Radiation : 016813000003457
EUT Stage	Production Unit

1.4 Product Specification of Equipment Under Test

Standards-related Product Specification	
Tx/Rx Frequency	5G NR n77: 3700 MHz ~ 3980 MHz 5G NR n78: 3700 MHz ~ 3800 MHz
SCS	30kHz
Bandwidth	n77/n78: 10 / 15 / 20 / 25 / 30 / 40 / 50 / 60 / 70 / 80 / 90 / 100MHz
Antenna Gain	<Ant. 2> 5G NR n77/n78: -3.0 dBi <Ant. 3> 5G NR n77/n78: -5.0 dBi <Ant. 4> 5G NR n77/n78: -3.0 dBi <Ant. 5> 5G NR n77/n78: -2.0 dBi
Type of Modulation	CP-OFDM: QPSK / 16QAM / 64QAM / 256QAM DFT-s-OFDM: PI/2 BPSK / QPSK / 16QAM / 64QAM / 256QAM

Remark:

1. The maximum EIRP is calculated from max output power and max antenna gain, only the maximum EIRP are shown in the report, 5G NR n77/n78 for Ant. 4.
2. For 5G NR n77/n78, only the test data of Ant.4 is showed in the report according to the maximum conducted power for conducted test items
3. 5G NR n77/n78 support SA and NSA mode. The whole testing has assessed SA mode for n77 by referring to the higher conducted power for conducted test items.
4. The device supports HPUE(PC2) mode for 5G NR n77/n78.



- 5. All the supported EN-DC combinations are verified conducted power, only the EN-DC combination with highest power are shown in the report.
- 6. The EN-DC mode combination could be referred to the product spec.

1.5 Modification of EUT

No modifications are made to the EUT during all test items.

1.6 Maximum EIRP and Emission Designator

5G NR n77 SA		PI/2 BPSK / QPSK		16QAM / 64QAM / 256QAM	
BW (MHz)	Frequency Range (MHz)	Maximum EIRP(W)	Emission Designator (99%OBW)	Maximum EIRP(W)	Emission Designator (99%OBW)
10	3705.00 ~ 3975.00	0.1754	8M59G7D	0.1303	8M60W7D
15	3705.52 ~ 3972.48	0.1799	13M6G7D	0.1432	13M6W7D
20	3710.01 ~ 3969.99	0.1799	18M3G7D	0.1377	18M2W7D
25	3712.50 ~ 3967.50	0.1849	23M1G7D	0.1355	23M1W7D
30	3715.02 ~ 3964.98	0.1849	27M9G7D	0.1352	27M9W7D
40	3720.00 ~ 3960.00	0.1862	38M0G7D	0.1396	37M9W7D
50	3725.01 ~ 3954.99	0.1897	47M3G7D	0.1419	47M5W7D
60	3730.02 ~ 3949.98	0.1879	57M7G7D	0.1429	57M7W7D
70	3735.00 ~ 3945.00	0.0650	67M6G7D	0.0530	67M7W7D
80	3740.01 ~ 3939.99	0.1897	77M3G7D	0.1469	77M4W7D
90	3745.02 ~ 3934.98	0.1766	87M3G7D	0.1330	87M3W7D
100	3750.00 ~ 3930.00	0.1824	97M0G7D	0.1371	97M2W7D



5G NR n78 SA		PI/2 BPSK / QPSK		16QAM / 64QAM / 256QAM	
BW (MHz)	Frequency Range (MHz)	Maximum EIRP(W)	Emission Designator (99%OBW)	Maximum EIRP(W)	Emission Designator (99%OBW)
10	3705.00 ~ 3795.00	0.1807	8M59G7D	0.1409	8M60W7D
15	3707.52 ~ 3792.48	0.1832	13M6G7D	0.1321	13M6W7D
20	3710.01 ~ 3789.99	0.1858	18M3G7D	0.1343	18M2W7D
25	3712.50 ~ 3787.50	0.1845	23M1G7D	0.1439	23M1W7D
30	3715.02 ~ 3784.98	0.1854	27M9G7D	0.1483	27M9W7D
40	3720.00 ~ 3780.00	0.1858	38M0G7D	0.1422	37M9W7D
50	3725.01 ~ 3774.99	0.1858	47M3G7D	0.1390	47M5W7D
60	3730.02 ~ 3769.98	0.1888	57M7G7D	0.1371	57M7W7D
70	3735.00 ~ 3765.00	0.0705	67M6G7D	0.0578	67M7W7D
80	3740.01 ~ 3759.99	0.1862	77M3G7D	0.1556	77M4W7D
90	3745.02 ~ 3754.98	0.1807	87M3G7D	0.1384	87M3W7D
100	3750.00 ~ 3750.00	0.1770	97M0G7D	0.1276	97M2W7D

Note:

- 5G NR Band n77 overlaps the entire frequency range of Band n78, and n77 power > n78 power, therefore the conducted test results of n77 provided in this report cover n78.
- All modulations have been tested, and only the worst test results of PSK & QAM are shown in the report.

1.7 Testing Location

Sporton International Inc. (Kunshan) is accredited to ISO/IEC 17025:2017 by American Association for Laboratory Accreditation with Certificate Number 5145.02.

Test Firm	Sporton International Inc. (Kunshan)		
Test Site Location	No. 1098, Pengxi North Road, Kunshan Economic Development Zone Jiangsu Province 215300 People's Republic of China TEL : +86-512-57900158		
Test Site No.	Sporton Site No.	FCC Designation No.	FCC Test Firm Registration No.
	03CH04-KS TH01-KS	CN1257	314309



1.8 Test Software

Item	Site	Manufacture	Name	Version
1.	TH01-KS	Tonscend	JS1120-3 test system China_210602	3.3.10
2.	03CH04-KS	AUDIX	E3	210616

1.9 Applicable Standards

According to the specifications of the manufacturer, the EUT must comply with the requirements of the following standards:

- ♦ 47 CFR Part 27
- ♦ ANSI C63.26-2015
- ♦ FCC KDB 971168 D01 Power Meas License Digital Systems v03r01
- ♦ FCC KDB 412172 D01 Determining ERP and EIRP v01r01

Remark:

All test items were verified and recorded according to the standards and without any deviation during the test.



2 Test Configuration of Equipment Under Test

2.1 Test Mode

Antenna port conducted and radiated test items are performed according to KDB 971168 D01 Power Meas License Digital Systems v03r01 with maximum output power.

For radiated measurement, pre-scanned in three orthogonal panels, X, Y, Z. The worst cases (Y plane) were recorded in this report.

The device is investigated from 30MHz to 10 times of fundamental signal for radiated spurious emission test under different RB size/offset and modulations in exploratory test. Subsequently, only the worst case emissions are reported.

Orthogonal Planes of EUT	X Plane	Y Plane	Z Plane
			

Test Items	5G NR	Bandwidth (MHz)										Modulation					RB #			Test Channel			
		10	15	20	25	30	40	50	60	70~90	100	PI/2 BPSK	QPSK	16QAM	64QAM	256 QAM	1	Partial	Full	L	M	H	
Max. Output Power	n77	v	v	v	v	v	v	v	v	v	v	v	v	v	v	v	v	v	v	v	v	v	v
	n78	v	v	v	v	v	v	v	v	v	v	v	v	v	v	v	v	v	v	v	v	v	v
Peak-to-Average Ratio	n77			v								v	v				v		v		v		
26dB and 99% Bandwidth	n77	v	v	v	v	v	v	v	v	v	v	v	v						v		v		
Conducted Band Edge	n77	v						v				v	v	v				v		v	v	v	
Conducted Spurious Emission	n77	v						v				v	v	v				v			v	v	
Frequency Stability	n77			v															v		v		
E.I.R.P	n77	v	v	v	v	v	v	v	v	v	v	v	v	v	v	v	v	v	v	v	v	v	
	n78	v	v	v	v	v	v	v	v	v	v	v	v	v	v	v	v	v	v	v	v	v	
Radiated Spurious Emission	n77	Worst Case																				v	
	n78	Worst Case																				v	
Note	1. The mark "v" means that this configuration is chosen for testing 2. The mark "-" means that this bandwidth is not supported. 3. The device is investigated from 30MHz to 10 times of fundamental signal for radiated spurious emission test under different RB size/offset and modulations in exploratory test. Subsequently, only the worst case emissions are reported. 4. Frequency Stability : Normal Voltage = 3.87V; Low Voltage =3.5V; High Voltage =4.45V.																						

2.2 Connection Diagram of Test System

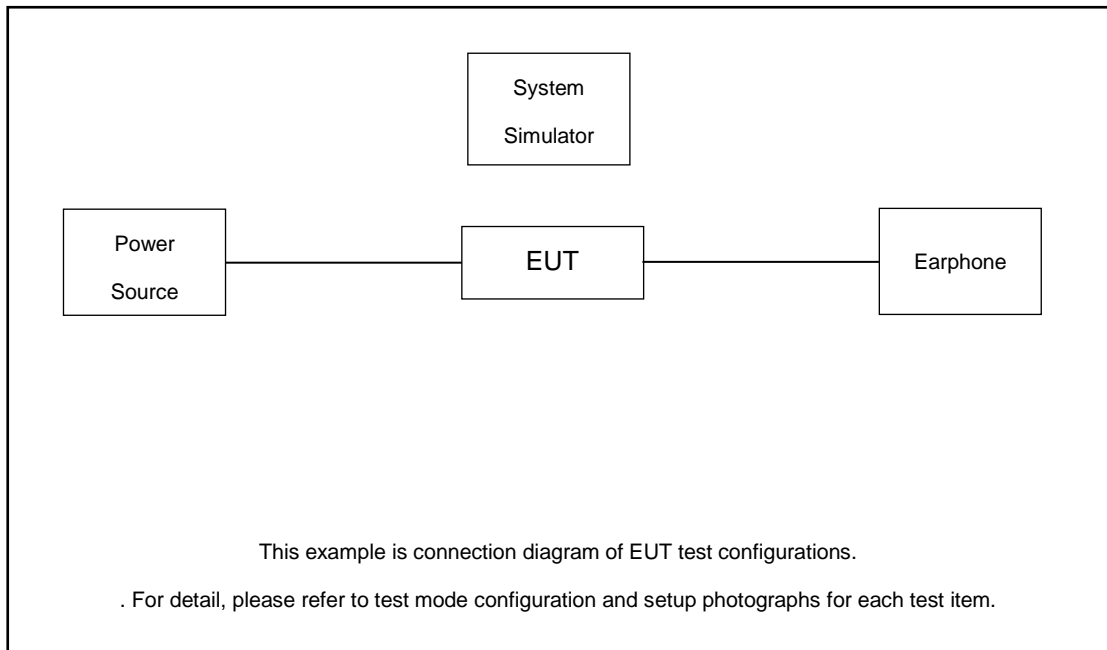

2.3 Support Unit used in test configuration and system

Item	Equipment	Trade Name	Model No.	FCC ID	Data Cable	Power Cord
1.	DC Power Supply	GW	GPS-3030D	N/A	N/A	Unshielded, 1.8 m
2.	LTE Base Station	Anritsu	MT8821C	N/A	N/A	Unshielded, 1.8 m
3.	NR Base Station	Anritsu	MT8000A	N/A	N/A	Unshielded, 1.8 m
4.	Earphone	N/A	N/A	N/A	N/A	N/A

2.4 Measurement Results Explanation Example

For all conducted test items:

The offset level is set in the spectrum analyzer to compensate the RF cable loss and attenuator factor between EUT conducted output port and spectrum analyzer. With the offset compensation, the spectrum analyzer reading level is exactly the EUT RF output level.

The spectrum analyzer offset is derived from RF cable loss and attenuator factor.

Offset = RF cable loss + attenuator factor.

Following shows an offset computation example with cable loss 6.8 dB and 10dB attenuator.

Example :

Offset(dB) = RF cable loss(dB) + attenuator factor(dB).

$$= 6.8 + 10 = 16.8 \text{ (dB)}$$



2.5 Frequency List of Low/Middle/High Channels

5G n77 Channel and Frequency List				
BW [MHz]	Channel/Frequency(MHz)	Lowest	Middle	Highest
100	Channel	650000	656000	662000
	Frequency	3750	3840	3930
90	Channel	649668	656000	662332
	Frequency	3745.02	3840	3934.98
80	Channel	649334	656000	662666
	Frequency	3740.01	3840	3939.99
70	Channel	649000	656000	663000
	Frequency	3735	3840	3945
60	Channel	648668	656000	663332
	Frequency	3730.02	3840	3949.98
50	Channel	648334	656000	663666
	Frequency	3725.01	3840	3954.99
40	Channel	648000	656000	664000
	Frequency	3720	3840	3960
30	Channel	647668	656000	664332
	Frequency	3715.02	3840	3964.98
25	Channel	647500	656000	664500
	Frequency	3712.5	3840	3967.5
20	Channel	647334	656000	664666
	Frequency	3710.01	3840	3969.99
15	Channel	647168	656000	664832
	Frequency	3707.52	3840	3972.48
10	Channel	647000	656000	665000
	Frequency	3705	3840	3975



5G n78 Channel and Frequency List				
BW [MHz]	Channel/Frequency(MHz)	Lowest	Middle	Highest
100	Channel	650000		
	Frequency	3750		
90	Channel	649668	650000	650332
	Frequency	3745.02	3750	3754.98
80	Channel	649334	650000	650666
	Frequency	3740.01	3750	3759.99
70	Channel	649000	650000	651000
	Frequency	3735	3750	3765
60	Channel	648668	650000	651332
	Frequency	3730.02	3750	3769.98
50	Channel	648334	650000	651666
	Frequency	3725.01	3750	3774.99
40	Channel	648000	650000	652000
	Frequency	3720	3750	3780
30	Channel	647668	650000	652332
	Frequency	3715.02	3750	3784.98
25	Channel	647500	650000	652500
	Frequency	3712.5	3750	3787.5
20	Channel	647334	650000	652666
	Frequency	3710.01	3750	3789.99
15	Channel	647168	650000	652832
	Frequency	3707.52	3750	3792.48
10	Channel	647000	650000	653000
	Frequency	3705	3750	3795

3 Conducted Test Items

3.1 Measuring Instruments

See list of measuring instruments of this test report.

3.2 Test Setup

3.2.1 Conducted Output Power

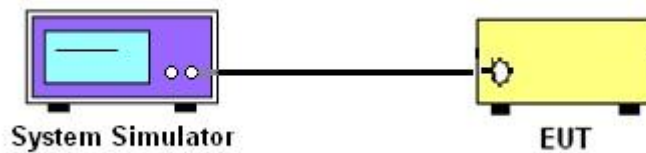

3.2.2 Peak-to-Average Ratio, Occupied Bandwidth, Conducted Band-Edge and Conducted Spurious Emission

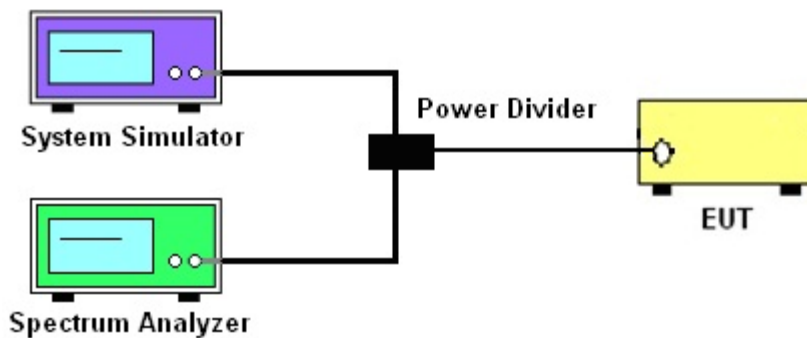

3.2.3 Frequency Stability

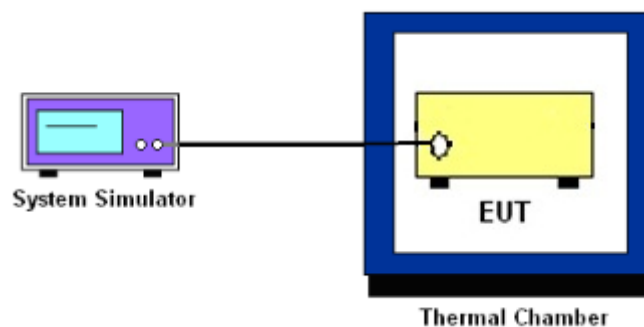

3.3 Test Result of Conducted Test

Please refer to Appendix A.



3.4 Conducted Output Power and EIRP

3.4.1 Description of the Conducted Output Power Measurement and EIRP Measurement

A system simulator was used to establish communication with the EUT. Its parameters were set to force the EUT transmitting at maximum output power. The measured power in the radio frequency on the transmitter output terminals shall be reported.

The EIRP of mobile transmitters must not exceed 1 Watts for 5G NR n77, n78.

According to KDB 412172 D01 Power Approach,

$EIRP = P_T + G_T - L_C$, $ERP = EIRP - 2.15$, where

P_T = transmitter output power in dBm

G_T = gain of the transmitting antenna in dBi

L_C = signal attenuation in the connecting cable between the transmitter and antenna in dB

3.4.2 Test Procedures

1. The testing follows ANSI C63.26 Section 5.2
2. The transmitter output port was connected to the system simulator.
3. Set EUT at maximum power through the system simulator.
4. Select lowest, middle, and highest channels for each band and different modulation.
5. Measure and record the power level from the system simulator.



3.5 Peak-to-Average Ratio

3.5.1 Description of the PAR Measurement

Power Complementary Cumulative Distribution Function (CCDF) curves provide a means for characterizing the power peaks of a digitally modulated signal on a statistical basis. A CCDF curve depicts the probability of the peak signal amplitude exceeding the average power level. Most contemporary measurement instrumentation include the capability to produce CCDF curves for an input signal provided that the instrument's resolution bandwidth can be set wide enough to accommodate the entire input signal bandwidth. In measuring transmissions in this band using an average power technique, the peak-to-average ratio (PAR) of the transmission may not exceed 13 dB.

3.5.2 Test Procedures

1. The testing follows ANSI C63.26 Section 5.2.3.4 (CCDF).
2. The EUT was connected to spectrum and system simulator via a power divider.
3. Set the CCDF (Complementary Cumulative Distribution Function) option in spectrum analyzer.
4. The highest RF powers were measured and recorded the maximum PAPR level associated with a probability of 0.1 %.
5. Record the deviation as Peak to Average Ratio.



3.6 Occupied Bandwidth

3.6.1 Description of Occupied Bandwidth Measurement

The occupied bandwidth is the width of a frequency band such that, below the lower and above the upper frequency limits, the mean powers emitted are each equal to a specified percentage 0.5% of the total mean transmitted power.

The 26 dB emission bandwidth is defined as the frequency range between two points, one above and one below the carrier frequency, at which the spectral density of the emission is attenuated 26 dB below the maximum in-band spectral density of the modulated signal. Spectral density (power per unit bandwidth) is to be measured with a detector of resolution bandwidth equal to approximately 1.0% of the emission bandwidth.

3.6.2 Test Procedures

1. The testing follows ANSI C63.26 Section 5.4
2. The EUT was connected to spectrum analyzer and system simulator via a power divider.
3. The spectrum analyzer center frequency is set to the nominal EUT channel center frequency. The span range for the spectrum analyzer shall be between two and five times the anticipated OBW.
4. The nominal resolution bandwidth (RBW) shall be in the range of 1 to 5 % of the anticipated OBW, and the VBW shall be at least 3 times the RBW.
5. Set the detection mode to peak, and the trace mode to max hold.
6. Determine the reference value: Set the EUT to transmit a modulated signal. Allow the trace to stabilize. Set the spectrum analyzer marker to the highest level of the displayed trace.
(this is the reference value)
7. Determine the “-26 dB down amplitude” as equal to (Reference Value – X).
8. Place two markers, one at the lowest and the other at the highest frequency of the envelope of the spectral display such that each marker is at or slightly below the “-X dB down amplitude” determined in step 6. If a marker is below this “-X dB down amplitude” value it shall be placed as close as possible to this value. The OBW is the positive frequency difference between the two markers.
9. Use the 99 % power bandwidth function of the spectrum analyzer and report the measured bandwidth.



3.7 Conducted Band Edge

3.7.1 Description of Conducted Band Edge Measurement

27.53(l)(2)

For mobile operations in the 3700-3980 MHz band, the conducted power of any emission outside the licensee's authorized bandwidth shall not exceed -13 dBm/MHz. Compliance with this paragraph is based on the use of measurement instrumentation employing a resolution bandwidth of 1 megahertz or greater. However, in the 1 megahertz bands immediately outside and adjacent to the licensee's frequency block, the minimum resolution bandwidth for the measurement shall be either one percent of the emission bandwidth of the fundamental emission of the transmitter or 350 kHz. In the bands between 1 and 5 MHz removed from the licensee's frequency block, the minimum resolution bandwidth for the measurement shall be 500 kHz.

3.7.2 Test Procedures

1. The testing follows ANSI C63.26 section 5.7
2. The EUT was connected to spectrum analyzer and system simulator via a power divider.
3. The band edges of low and high channels for the highest RF powers were measured.
4. Set RBW \geq 1% EBW in the 1MHz band immediately outside and adjacent to the band edge.
5. Beyond the 1 MHz band from the band edge, RBW=1MHz was used or a narrower RBW was used (generally limited to no less than 1% of the OBW) and the measured power was integrated over the full required measurement bandwidth.
6. Set spectrum analyzer with RMS detector.
7. The RF fundamental frequency should be excluded against the limit line in the operating frequency band.
8. Checked that all the results comply with the emission limit line.

Example:

$$\begin{aligned} & \text{The limit line is derived from } 43 + 10\log(P)\text{dB below the transmitter power } P(\text{Watts}) \\ & = P(\text{W}) - [43 + 10\log(P)] \text{ (dB)} \\ & = [30 + 10\log(P)] \text{ (dBm)} - [43 + 10\log(P)] \text{ (dB)} = -13\text{dBm.} \end{aligned}$$

9. When using the integration method, the starting frequency of the integration shall be centered at one-half of the RBW away from the band edge.



3.8 Conducted Spurious Emission

3.8.1 Description of Conducted Spurious Emission Measurement

The power of any emission outside of the authorized operating frequency ranges must be lower than the transmitter power (P) by a factor of at least $43 + 10 \log (P)$ dB.

It is measured by means of a calibrated spectrum analyzer and scanned from 30 MHz up to a frequency including its 10th harmonic.

3.8.2 Test Procedures

1. The testing follows ANSI C63.26 section 5.7
2. The EUT was connected to spectrum analyzer and system simulator via a power divider.
3. The RF output of EUT was connected to the spectrum analyzer by RF cable and attenuator. The path loss was compensated to the results for each measurement.
4. The middle channel for the highest RF power within the transmitting frequency was measured.
5. The conducted spurious emission for the whole frequency range was taken.
6. Make the measurement with the spectrum analyzer's RBW = 1MHz, VBW = 3MHz.
7. Set spectrum analyzer with RMS detector.
8. Taking the record of maximum spurious emission.
9. The RF fundamental frequency should be excluded against the limit line in the operating frequency band.
10. The limit line is derived from $43 + 10\log(P)$ dB below the transmitter power P(Watts)
= P(W)- [43 + 10log(P)] (dB)
= [30 + 10log(P)] (dBm) - [43 + 10log(P)] (dB)
= -13dBm.



3.9 Frequency Stability

3.9.1 Description of Frequency Stability Measurement

The frequency stability shall be measured by variation of ambient temperature and variation of primary supply voltage to ensure that the fundamental emission stays within the authorized frequency block. The frequency stability of the transmitter shall be maintained within $\pm 0.00025\%$ ($\pm 2.5\text{ppm}$) of the center frequency.

3.9.2 Test Procedures for Temperature Variation

1. The testing follows ANSI C63.26 section 5.6.4
2. The EUT was set up in the thermal chamber and connected with the system simulator.
3. With power OFF, the temperature was decreased to -30°C and the EUT was stabilized before testing. Power was applied and the maximum change in frequency was recorded within one minute.
4. With power OFF, the temperature was raised in 10°C step up to 50°C . The EUT was stabilized at each step for at least half an hour. Power was applied and the maximum frequency change was recorded within one minute.

3.9.3 Test Procedures for Voltage Variation

1. The testing follows ANSI C63.26 section 5.6.5
2. The EUT was placed in a temperature chamber at $20\pm 5^{\circ}\text{C}$ and connected with the system simulator.
3. The power supply voltage to the EUT was varied from 85% to 115% of the nominal value for other than hand carried battery equipment.
4. For hand carried, battery powered equipment, reduce the primary ac or dc supply voltage to the battery operating end point, which shall be specified by the manufacturer.
5. The variation in frequency was measured for the worst case.

4 Radiated Test Items

4.1 Measuring Instruments

See list of measuring instruments of this test report.

4.2 Test Setup

4.2.1 For radiated test below 30MHz

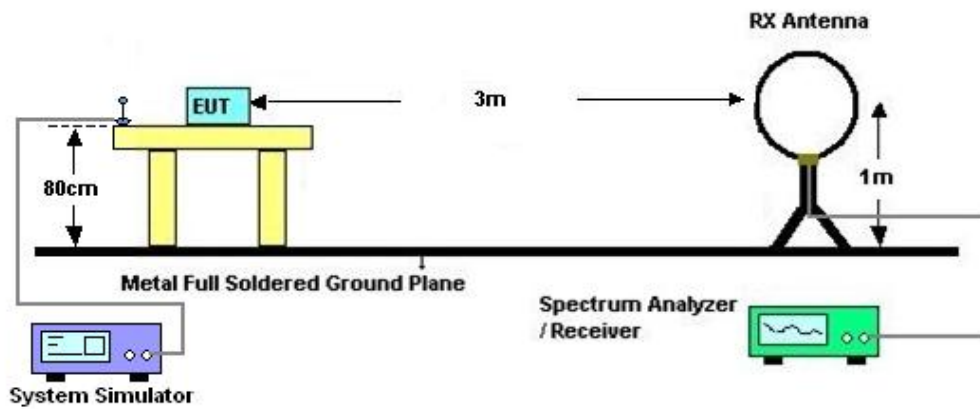

4.2.2 For radiated test from 30MHz to 1GHz

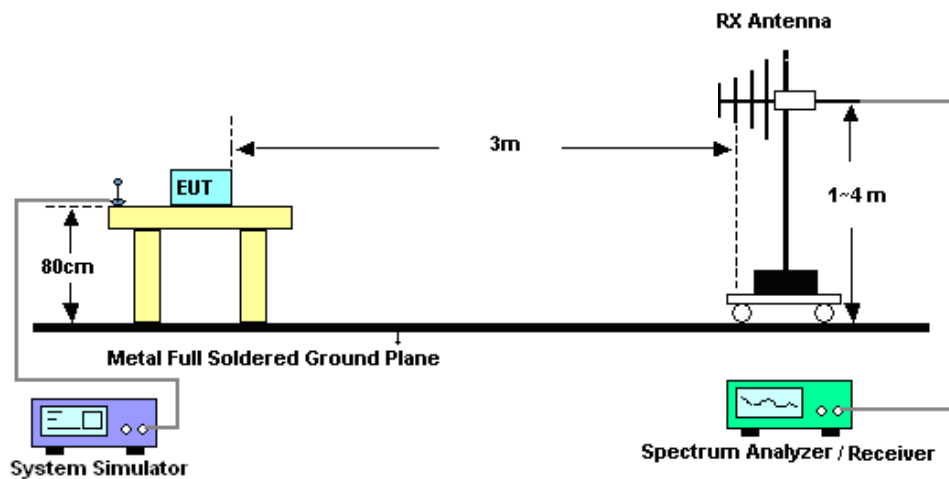

4.2.3 For radiated test above 1GHz

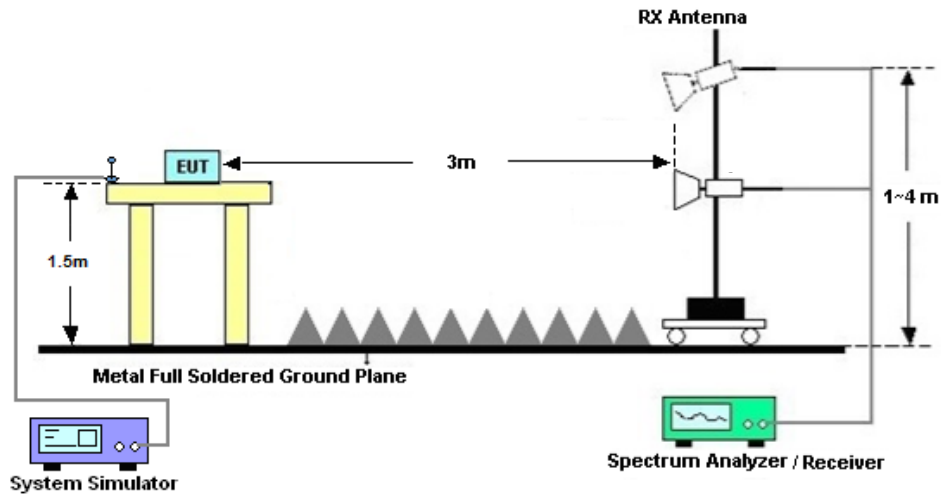

4.3 Test Result of Radiated Test

The low frequency, which started from 9 kHz to 30MHz, was pre-scanned and the result which was 20dB lower than the limit line was not reported.

Please refer to Appendix B.



4.4 Radiated Spurious Emission

4.4.1 Description of Radiated Spurious Emission

The radiated spurious emission was measured by substitution method according to ANSI C63.26. The power of any emission outside of the authorized operating frequency ranges must be attenuated below the transmitter power (P) by a factor of at least $43 + 10 \log (P)$ dB.

The spectrum is scanned from 30 MHz up to a frequency including its 10th harmonic.

4.4.2 Test Procedures

1. The testing follows ANSI C63.26 Section 5.5
2. The EUT was placed on a turntable with 0.8 meter height for frequency below 1GHz and 1.5 meter height for frequency above 1GHz respectively above ground.
3. The EUT was set 3 meters from the receiving antenna mounted on the antenna tower.
4. The table was rotated 360 degrees to determine the position of the highest spurious emission.
5. The height of the receiving antenna is varied between 1m to 4m to search the maximum spurious emission for both horizontal and vertical polarizations.
6. During the measurement, the system simulator parameters were set to force the EUT transmitting at maximum output power.
7. Make the measurement with the spectrum analyzer's RBW = 1MHz, VBW = 3MHz, taking the record of maximum spurious emission.
8. A horn antenna was substituted in place of the EUT and was driven by a signal generator.
9. Tune the output power of signal generator to the same emission level with EUT maximum spurious emission.
10. $EIRP (dBm) = S.G. Power - Tx Cable Loss + Tx Antenna Gain$
11. $ERP (dBm) = EIRP - 2.15$
12. The RF fundamental frequency should be excluded against the limit line in the operating frequency band.

The limit line is derived from $43 + 10\log(P)$ dB below the transmitter power P(Watts)
= $P(W) - [43 + 10\log(P)] (dB)$
= $[30 + 10\log(P)] (dBm) - [43 + 10\log(P)] (dB)$
= -13dBm.



5 List of Measuring Equipment

Instrument	Manufacturer	Model No.	Serial No.	Characteristics	Calibration Date	Test Date	Due Date	Remark
EXA Spectrum Analyzer	Keysight	N9010A	MY55370528	10Hz-44G,MAX 30dB	Oct. 10, 2025	Mar. 15, 2026	Oct. 09, 2026	Radiation (03CH04-KS)
Active loop antenna	R&S	HFH2-Z2E	101125	9kHz~30MHz	Aug. 10, 2025	Mar. 15, 2026	Aug. 09, 2026	Radiation (03CH04-KS)
Bilog Antenna	TeseQ	CBL6111D	44483	30MHz-1GHz	Nov. 22, 2025	Mar. 15, 2026	Nov. 21, 2026	Radiation (03CH04-KS)
Double Ridge Horn Antenna	ETS-Lindgren	3117	00227860	1GHz~18GHz	Aug. 22, 2025	Mar. 15, 2026	Aug. 21, 2026	Radiation (03CH04-KS)
SHF-EHF Horn	Com-power	AH-840	101070	18GHz~40GHz	Jan. 10, 2026	Mar. 15, 2026	Jan. 09, 2027	Radiation (03CH04-KS)
Amplifier	SONOMA	310N	380826	9KHz-1GHz	Jul. 02, 2025	Mar. 15, 2026	Jul. 01, 2026	Radiation (03CH04-KS)
Amplifier	EM	EM18G40G A	060852	18~40GHz	Dec. 24, 2025	Mar. 15, 2026	Dec. 23, 2026	Radiation (03CH04-KS)
high gain Amplifier	EM	EM01G18G A	060890	1Ghz-18Ghz	May 23, 2025	Mar. 15, 2026	May 22, 2026	Radiation (03CH04-KS)
Amplifier	EM	EM01G18G A	060892	1Ghz-18Ghz	Oct. 11, 2025	Mar. 15, 2026	Oct. 10, 2026	Radiation (03CH04-KS)
AC Power Source	Chroma	61601	F104090004	N/A	NCR	Mar. 15, 2026	NCR	Radiation (03CH04-KS)
Turn Table	ChamPro	EM 1000-T	060762-T	0~360 degree	NCR	Mar. 15, 2026	NCR	Radiation (03CH04-KS)
Antenna Mast	ChamPro	EM 1000-A	060762-A	1 m~4 m	NCR	Mar. 15, 2026	NCR	Radiation (03CH04-KS)
Spectrum Analyzer	R&S	FSV40	101040	10Hz~40GHz	Jul. 07, 2025	Mar. 05, 2026	Jul. 06, 2026	Conducted (TH01-KS)
Power divider	STI	STI08-0055	-	0.5~40GHz	NCR	Mar. 05, 2026	NCR	Conducted (TH01-KS)
Radio communication analyzer	Anritsu	MT8821C	6261806798	2G/3G/LTE band 1-46 ,48,65-70	Jul. 03, 2025	Mar. 05, 2026	Jul. 02, 2026	Conducted (TH01-KS)
Temperature & humidity chamber	Hongzhan	LP-150U	H2014011440	-40~+150°C 20%~95%RH	Jul. 02, 2025	Mar. 05, 2026	Jul. 01, 2026	Conducted (TH01-KS)

NCR: No Calibration Required



6 Measurement Uncertainty

The measurement uncertainties shown below were calculated in accordance with the requirements of ANSI 63.26-2015. All the measurement uncertainty value were shown with a coverage K=2 to indicate 95% level of confidence. The measurement data show herein meets or exceeds the CISPR measurement uncertainty values specified in CISPR 16-4-2 and can be compared directly to specified limit to determine compliance.

Uncertainty of Conducted Measurement

Conducted Spurious Emission & Bandedge	±2.00 dB
Occupied Channel Bandwidth	±0.384%
Conducted Power	±0.90 dB
Peak to Average Ratio	±0.90 dB
Frequency Stability	±0.38 ppm

Uncertainty of Radiated Emission Measurement (30 MHz ~ 1 GHz)

Measuring Uncertainty for a Level of Confidence of 95% (U = 2Uc(y))	2.83dB
---	--------

Uncertainty of Radiated Emission Measurement (1 GHz ~ 18 GHz)

Measuring Uncertainty for a Level of Confidence of 95% (U = 2Uc(y))	2.83dB
---	--------

Uncertainty of Radiated Emission Measurement (18 GHz ~ 40 GHz)

Measuring Uncertainty for a Level of Confidence of 95% (U = 2Uc(y))	2.82dB
---	--------

----- THE END -----



Appendix A. Test Results of Conducted Test

Test Engineer :	Simle Wang	Temperature :	22~23°C
		Relative Humidity :	40~42%



Software Version: 23.06.1602

FR1 N77_ANT4

Transmitter Conducted Output Power And EIRP, (G_T - L_c)= -3.0 dB

NR Band	SCS	BandWidth	Arfcn	Freq(MHz)	Modulation	RB	Conducted Power(dBm)	EIRP(dBm)	EIRP(W)
77	30	10	647000	3705	DFT-s-OFDM PI/2 BPSK	1@1	25.29	22.29	0.1694
77	30	10	647000	3705	DFT-s-OFDM QPSK	1@1	25.26	22.26	0.1683
77	30	10	647000	3705	DFT-s-OFDM 16 QAM	1@1	24.15	21.15	0.1303
77	30	10	656000	3840	DFT-s-OFDM PI/2 BPSK	1@1	25.39	22.39	0.1734
77	30	10	656000	3840	DFT-s-OFDM QPSK	1@1	25.44	22.44	0.1754
77	30	10	656000	3840	DFT-s-OFDM 16 QAM	1@1	24.09	21.09	0.1285
77	30	10	665000	3975	DFT-s-OFDM PI/2 BPSK	1@1	25.21	22.21	0.1663
77	30	10	665000	3975	DFT-s-OFDM QPSK	1@1	25.23	22.23	0.1671
77	30	10	665000	3975	DFT-s-OFDM 16 QAM	1@1	24.01	21.01	0.1262
77	30	15	647168	3707.52	DFT-s-OFDM PI/2 BPSK	1@1	25.22	22.22	0.1667
77	30	15	647168	3707.52	DFT-s-OFDM QPSK	1@1	25.25	22.25	0.1679
77	30	15	647168	3707.52	DFT-s-OFDM 16 QAM	1@1	24.30	21.30	0.1349
77	30	15	656000	3840	DFT-s-OFDM PI/2 BPSK	1@1	25.55	22.55	0.1799
77	30	15	656000	3840	DFT-s-OFDM QPSK	1@1	25.55	22.55	0.1799
77	30	15	656000	3840	DFT-s-OFDM 16 QAM	1@1	24.56	21.56	0.1432
77	30	15	664832	3972.48	DFT-s-OFDM PI/2 BPSK	1@1	25.13	22.13	0.1633
77	30	15	664832	3972.48	DFT-s-OFDM QPSK	1@1	25.12	22.12	0.1629
77	30	15	664832	3972.48	DFT-s-OFDM 16 QAM	1@1	24.28	21.28	0.1343
77	30	20	647334	3710.01	DFT-s-OFDM PI/2 BPSK	1@1	25.33	22.33	0.1710
77	30	20	647334	3710.01	DFT-s-OFDM QPSK	1@1	25.31	22.31	0.1702
77	30	20	647334	3710.01	DFT-s-OFDM 16 QAM	1@1	24.39	21.39	0.1377
77	30	20	656000	3840	DFT-s-OFDM PI/2 BPSK	1@1	25.49	22.49	0.1774
77	30	20	656000	3840	DFT-s-OFDM QPSK	1@1	25.55	22.55	0.1799
77	30	20	656000	3840	DFT-s-OFDM 16 QAM	1@1	24.20	21.20	0.1318
77	30	20	664666	3969.99	DFT-s-OFDM PI/2 BPSK	1@1	25.21	22.21	0.1663
77	30	20	664666	3969.99	DFT-s-OFDM QPSK	1@1	25.26	22.26	0.1683
77	30	20	664666	3969.99	DFT-s-OFDM 16 QAM	1@1	23.87	20.87	0.1222
77	30	25	647500	3712.5	DFT-s-OFDM PI/2 BPSK	1@1	25.28	22.28	0.1690
77	30	25	647500	3712.5	DFT-s-OFDM QPSK	1@1	25.24	22.24	0.1675
77	30	25	647500	3712.5	DFT-s-OFDM 16 QAM	1@1	24.31	21.31	0.1352



77	30	25	656000	3840	DFT-s-OFDM PI/2 BPSK	1@1	25.56	22.56	0.1803
77	30	25	656000	3840	DFT-s-OFDM QPSK	1@1	25.67	22.67	0.1849
77	30	25	656000	3840	DFT-s-OFDM 16 QAM	1@1	24.32	21.32	0.1355
77	30	25	664500	3967.5	DFT-s-OFDM PI/2 BPSK	1@1	25.22	22.22	0.1667
77	30	25	664500	3967.5	DFT-s-OFDM QPSK	1@1	25.32	22.32	0.1706
77	30	25	664500	3967.5	DFT-s-OFDM 16 QAM	1@1	23.93	20.93	0.1239
77	30	30	647668	3715.02	DFT-s-OFDM PI/2 BPSK	1@1	25.27	22.27	0.1687
77	30	30	647668	3715.02	DFT-s-OFDM QPSK	1@1	25.30	22.30	0.1698
77	30	30	647668	3715.02	DFT-s-OFDM 16 QAM	1@1	24.28	21.28	0.1343
77	30	30	656000	3840	DFT-s-OFDM PI/2 BPSK	1@1	25.58	22.58	0.1811
77	30	30	656000	3840	DFT-s-OFDM QPSK	1@1	25.67	22.67	0.1849
77	30	30	656000	3840	DFT-s-OFDM 16 QAM	1@1	24.31	21.31	0.1352
77	30	30	664332	3964.98	DFT-s-OFDM PI/2 BPSK	1@1	25.06	22.06	0.1607
77	30	30	664332	3964.98	DFT-s-OFDM QPSK	1@1	25.10	22.10	0.1622
77	30	30	664332	3964.98	DFT-s-OFDM 16 QAM	1@1	23.89	20.89	0.1227
77	30	40	648000	3720	DFT-s-OFDM PI/2 BPSK	1@1	25.24	22.24	0.1675
77	30	40	648000	3720	DFT-s-OFDM QPSK	1@1	25.30	22.30	0.1698
77	30	40	648000	3720	DFT-s-OFDM 16 QAM	1@1	24.04	21.04	0.1271
77	30	40	656000	3840	DFT-s-OFDM PI/2 BPSK	1@1	25.63	22.63	0.1832
77	30	40	656000	3840	DFT-s-OFDM QPSK	1@1	25.70	22.70	0.1862
77	30	40	656000	3840	DFT-s-OFDM 16 QAM	1@1	24.45	21.45	0.1396
77	30	40	664000	3960	DFT-s-OFDM PI/2 BPSK	1@1	24.95	21.95	0.1567
77	30	40	664000	3960	DFT-s-OFDM QPSK	1@1	25.03	22.03	0.1596
77	30	40	664000	3960	DFT-s-OFDM 16 QAM	1@1	23.74	20.74	0.1186
77	30	50	648334	3725.01	DFT-s-OFDM PI/2 BPSK	1@1	25.29	22.29	0.1694
77	30	50	648334	3725.01	DFT-s-OFDM QPSK	1@1	25.46	22.46	0.1762
77	30	50	648334	3725.01	DFT-s-OFDM 16 QAM	1@1	24.12	21.12	0.1294
77	30	50	656000	3840	DFT-s-OFDM PI/2 BPSK	1@1	25.78	22.78	0.1897
77	30	50	656000	3840	DFT-s-OFDM QPSK	1@1	25.78	22.78	0.1897
77	30	50	656000	3840	DFT-s-OFDM 16 QAM	1@1	24.52	21.52	0.1419
77	30	50	663666	3954.99	DFT-s-OFDM PI/2 BPSK	1@1	24.85	21.85	0.1531
77	30	50	663666	3954.99	DFT-s-OFDM QPSK	1@1	25.04	22.04	0.1600
77	30	50	663666	3954.99	DFT-s-OFDM 16 QAM	1@1	23.65	20.65	0.1161
77	30	60	648668	3730.02	DFT-s-OFDM PI/2 BPSK	1@1	25.26	22.26	0.1683
77	30	60	648668	3730.02	DFT-s-OFDM QPSK	1@1	25.36	22.36	0.1722
77	30	60	648668	3730.02	DFT-s-OFDM 16 QAM	1@1	24.31	21.31	0.1352



77	30	60	656000	3840	DFT-s-OFDM PI/2 BPSK	1@1	25.73	22.73	0.1875
77	30	60	656000	3840	DFT-s-OFDM QPSK	1@1	25.74	22.74	0.1879
77	30	60	656000	3840	DFT-s-OFDM 16 QAM	1@1	24.55	21.55	0.1429
77	30	60	663332	3949.98	DFT-s-OFDM PI/2 BPSK	1@1	25.15	22.15	0.1641
77	30	60	663332	3949.98	DFT-s-OFDM QPSK	1@1	25.27	22.27	0.1687
77	30	60	663332	3949.98	DFT-s-OFDM 16 QAM	1@1	23.89	20.89	0.1227
77	30	70	649000	3735	DFT-s-OFDM PI/2 BPSK	1@1	20.44	17.44	0.0555
77	30	70	649000	3735	DFT-s-OFDM QPSK	1@1	20.39	17.39	0.0548
77	30	70	649000	3735	DFT-s-OFDM 16 QAM	1@1	19.54	16.54	0.0451
77	30	70	656000	3840	DFT-s-OFDM PI/2 BPSK	1@1	20.93	17.93	0.0621
77	30	70	656000	3840	DFT-s-OFDM QPSK	1@1	20.90	17.90	0.0617
77	30	70	656000	3840	DFT-s-OFDM 16 QAM	1@1	19.97	16.97	0.0498
77	30	70	663000	3945	DFT-s-OFDM PI/2 BPSK	1@1	21.13	18.13	0.0650
77	30	70	663000	3945	DFT-s-OFDM QPSK	1@1	20.98	17.98	0.0628
77	30	70	663000	3945	DFT-s-OFDM 16 QAM	1@1	20.24	17.24	0.0530
77	30	80	649334	3740.01	DFT-s-OFDM PI/2 BPSK	1@1	25.32	22.32	0.1706
77	30	80	649334	3740.01	DFT-s-OFDM QPSK	1@1	25.33	22.33	0.1710
77	30	80	649334	3740.01	DFT-s-OFDM 16 QAM	1@1	24.34	21.34	0.1361
77	30	80	656000	3840	DFT-s-OFDM PI/2 BPSK	1@1	25.75	22.75	0.1884
77	30	80	656000	3840	DFT-s-OFDM QPSK	1@1	25.78	22.78	0.1897
77	30	80	656000	3840	DFT-s-OFDM 16 QAM	1@1	24.67	21.67	0.1469
77	30	80	662666	3939.99	DFT-s-OFDM PI/2 BPSK	1@1	25.44	22.44	0.1754
77	30	80	662666	3939.99	DFT-s-OFDM QPSK	1@1	25.49	22.49	0.1774
77	30	80	662666	3939.99	DFT-s-OFDM 16 QAM	1@1	24.11	21.11	0.1291
77	30	90	649668	3745.02	DFT-s-OFDM PI/2 BPSK	1@1	25.34	22.34	0.1714
77	30	90	649668	3745.02	DFT-s-OFDM QPSK	1@1	25.47	22.47	0.1766
77	30	90	649668	3745.02	DFT-s-OFDM 16 QAM	1@1	24.24	21.24	0.1330
77	30	90	656000	3840	DFT-s-OFDM PI/2 BPSK	1@1	24.43	21.43	0.1390
77	30	90	656000	3840	DFT-s-OFDM QPSK	1@1	24.61	21.61	0.1449
77	30	90	656000	3840	DFT-s-OFDM 16 QAM	1@1	23.24	20.24	0.1057
77	30	90	662332	3934.98	DFT-s-OFDM PI/2 BPSK	1@1	25.36	22.36	0.1722
77	30	90	662332	3934.98	DFT-s-OFDM QPSK	1@1	25.33	22.33	0.1710
77	30	90	662332	3934.98	DFT-s-OFDM 16 QAM	1@1	24.03	21.03	0.1268
77	30	100	650000	3750	DFT-s-OFDM PI/2 BPSK	1@1	25.35	22.35	0.1718
77	30	100	650000	3750	DFT-s-OFDM PI/2 BPSK	1@0	23.35	20.35	0.1084
77	30	100	650000	3750	DFT-s-OFDM PI/2 BPSK	1@271	25.54	22.54	0.1795



77	30	100	650000	3750	DFT-s-OFDM PI/2 BPSK	2@0	23.32	20.32	0.1076
77	30	100	650000	3750	DFT-s-OFDM PI/2 BPSK	135@67	25.56	22.56	0.1803
77	30	100	650000	3750	DFT-s-OFDM PI/2 BPSK	2@271	23.50	20.50	0.1122
77	30	100	650000	3750	DFT-s-OFDM PI/2 BPSK	270@0	23.53	20.53	0.1130
77	30	100	650000	3750	DFT-s-OFDM QPSK	1@1	25.33	22.33	0.1710
77	30	100	650000	3750	DFT-s-OFDM QPSK	1@0	23.42	20.42	0.1102
77	30	100	650000	3750	DFT-s-OFDM QPSK	1@271	25.48	22.48	0.1770
77	30	100	650000	3750	DFT-s-OFDM QPSK	2@0	23.33	20.33	0.1079
77	30	100	650000	3750	DFT-s-OFDM QPSK	135@67	25.61	22.61	0.1824
77	30	100	650000	3750	DFT-s-OFDM QPSK	2@271	23.53	20.53	0.1130
77	30	100	650000	3750	DFT-s-OFDM QPSK	270@0	23.12	20.12	0.1028
77	30	100	650000	3750	DFT-s-OFDM 16 QAM	1@1	24.33	21.33	0.1358
77	30	100	650000	3750	DFT-s-OFDM 64 QAM	1@1	23.60	20.60	0.1148
77	30	100	650000	3750	DFT-s-OFDM 256 QAM	1@1	21.17	18.17	0.0656
77	30	100	650000	3750	DFT-s-OFDM 16 QAM	270@0	22.18	19.18	0.0828
77	30	100	650000	3750	DFT-s-OFDM 64 QAM	270@0	21.69	18.69	0.0740
77	30	100	650000	3750	DFT-s-OFDM 256 QAM	270@0	18.64	15.64	0.0366
77	30	100	650000	3750	CP-OFDM QPSK	1@1	23.89	20.89	0.1227
77	30	100	650000	3750	CP-OFDM 16 QAM	1@1	23.23	20.23	0.1054
77	30	100	656000	3840	DFT-s-OFDM PI/2 BPSK	1@1	24.46	21.46	0.1400
77	30	100	656000	3840	DFT-s-OFDM PI/2 BPSK	1@0	22.49	19.49	0.0889
77	30	100	656000	3840	DFT-s-OFDM PI/2 BPSK	1@271	25.00	22.00	0.1585
77	30	100	656000	3840	DFT-s-OFDM PI/2 BPSK	2@0	22.46	19.46	0.0883
77	30	100	656000	3840	DFT-s-OFDM PI/2 BPSK	135@67	25.35	22.35	0.1718
77	30	100	656000	3840	DFT-s-OFDM PI/2 BPSK	2@271	22.97	19.97	0.0993
77	30	100	656000	3840	DFT-s-OFDM PI/2 BPSK	270@0	23.25	20.25	0.1059
77	30	100	656000	3840	DFT-s-OFDM QPSK	1@1	24.55	21.55	0.1429
77	30	100	656000	3840	DFT-s-OFDM QPSK	1@0	22.51	19.51	0.0893
77	30	100	656000	3840	DFT-s-OFDM QPSK	1@271	25.05	22.05	0.1603
77	30	100	656000	3840	DFT-s-OFDM QPSK	2@0	22.40	19.40	0.0871
77	30	100	656000	3840	DFT-s-OFDM QPSK	135@67	25.39	22.39	0.1734
77	30	100	656000	3840	DFT-s-OFDM QPSK	2@271	22.94	19.94	0.0986
77	30	100	656000	3840	DFT-s-OFDM QPSK	270@0	22.81	19.81	0.0957
77	30	100	656000	3840	DFT-s-OFDM 16 QAM	1@1	23.27	20.27	0.1064
77	30	100	656000	3840	DFT-s-OFDM 64 QAM	1@1	22.59	19.59	0.0910
77	30	100	656000	3840	DFT-s-OFDM 256 QAM	1@1	20.18	17.18	0.0522



77	30	100	656000	3840	DFT-s-OFDM 16 QAM	270@0	21.81	18.81	0.0760
77	30	100	656000	3840	DFT-s-OFDM 64 QAM	270@0	21.37	18.37	0.0687
77	30	100	656000	3840	DFT-s-OFDM 256 QAM	270@0	18.52	15.52	0.0356
77	30	100	656000	3840	CP-OFDM QPSK	1@1	22.93	19.93	0.0984
77	30	100	656000	3840	CP-OFDM 16 QAM	1@1	22.33	19.33	0.0857
77	30	100	662000	3930	DFT-s-OFDM PI/2 BPSK	1@1	25.27	22.27	0.1687
77	30	100	662000	3930	DFT-s-OFDM PI/2 BPSK	1@0	23.33	20.33	0.1079
77	30	100	662000	3930	DFT-s-OFDM PI/2 BPSK	1@271	25.15	22.15	0.1641
77	30	100	662000	3930	DFT-s-OFDM PI/2 BPSK	2@0	23.27	20.27	0.1064
77	30	100	662000	3930	DFT-s-OFDM PI/2 BPSK	135@67	24.94	21.94	0.1563
77	30	100	662000	3930	DFT-s-OFDM PI/2 BPSK	2@271	23.09	20.09	0.1021
77	30	100	662000	3930	DFT-s-OFDM PI/2 BPSK	270@0	23.07	20.07	0.1016
77	30	100	662000	3930	DFT-s-OFDM QPSK	1@1	25.38	22.38	0.1730
77	30	100	662000	3930	DFT-s-OFDM QPSK	1@0	23.33	20.33	0.1079
77	30	100	662000	3930	DFT-s-OFDM QPSK	1@271	25.27	22.27	0.1687
77	30	100	662000	3930	DFT-s-OFDM QPSK	2@0	23.26	20.26	0.1062
77	30	100	662000	3930	DFT-s-OFDM QPSK	135@67	24.97	21.97	0.1574
77	30	100	662000	3930	DFT-s-OFDM QPSK	2@271	23.11	20.11	0.1026
77	30	100	662000	3930	DFT-s-OFDM QPSK	270@0	22.61	19.61	0.0914
77	30	100	662000	3930	DFT-s-OFDM 16 QAM	1@1	24.37	21.37	0.1371
77	30	100	662000	3930	DFT-s-OFDM 64 QAM	1@1	23.72	20.72	0.1180
77	30	100	662000	3930	DFT-s-OFDM 256 QAM	1@1	21.15	18.15	0.0653
77	30	100	662000	3930	DFT-s-OFDM 16 QAM	270@0	21.63	18.63	0.0729
77	30	100	662000	3930	DFT-s-OFDM 64 QAM	270@0	21.19	18.19	0.0659
77	30	100	662000	3930	DFT-s-OFDM 256 QAM	270@0	18.29	15.29	0.0338
77	30	100	662000	3930	CP-OFDM QPSK	1@1	23.86	20.86	0.1219
77	30	100	662000	3930	CP-OFDM 16 QAM	1@1	22.91	19.91	0.0979



Frequency Stability

NR Band	SCS (kHz)	Bandwidth (MHz)	Arfcn	Freq (MHz)	Modulation	RB	Deviation (ppm)	Verdict	Environment
77	30	20	656000	3840.0	DFT-s-OFDM QPSK	50@0	0.0019	PASS	NV
77	30	20	656000	3840.0	DFT-s-OFDM QPSK	50@0	0.0018	PASS	LV
77	30	20	656000	3840.0	DFT-s-OFDM QPSK	50@0	0.0011	PASS	HV
77	30	20	656000	3840.0	DFT-s-OFDM QPSK	50@0	0.0000	PASS	-30°C
77	30	20	656000	3840.0	DFT-s-OFDM QPSK	50@0	0.0015	PASS	-20°C
77	30	20	656000	3840.0	DFT-s-OFDM QPSK	50@0	0.0021	PASS	-10°C
77	30	20	656000	3840.0	DFT-s-OFDM QPSK	50@0	0.0022	PASS	0°C
77	30	20	656000	3840.0	DFT-s-OFDM QPSK	50@0	0.0013	PASS	10°C
77	30	20	656000	3840.0	DFT-s-OFDM QPSK	50@0	0.0029	PASS	20°C
77	30	20	656000	3840.0	DFT-s-OFDM QPSK	50@0	0.0023	PASS	30°C
77	30	20	656000	3840.0	DFT-s-OFDM QPSK	50@0	0.0015	PASS	40°C
77	30	20	656000	3840.0	DFT-s-OFDM QPSK	50@0	0.0016	PASS	50°C



Peak to Average Ratio

Test Result

NR Band	SCS	BandWidth	Arfcn	Freq(MHz)	Modulation	RB	Result	Verdict
77	30	20	656000	3840.0	DFT-s-OFDM PI/2 BPSK	50@0	4.3	13
77	30	20	656000	3840.0	DFT-s-OFDM PI/2 BPSK	1@0	3.53	13
77	30	20	656000	3840.0	DFT-s-OFDM QPSK	50@0	5.3	13
77	30	20	656000	3840.0	DFT-s-OFDM QPSK	1@0	4.4	13



Test Graphs

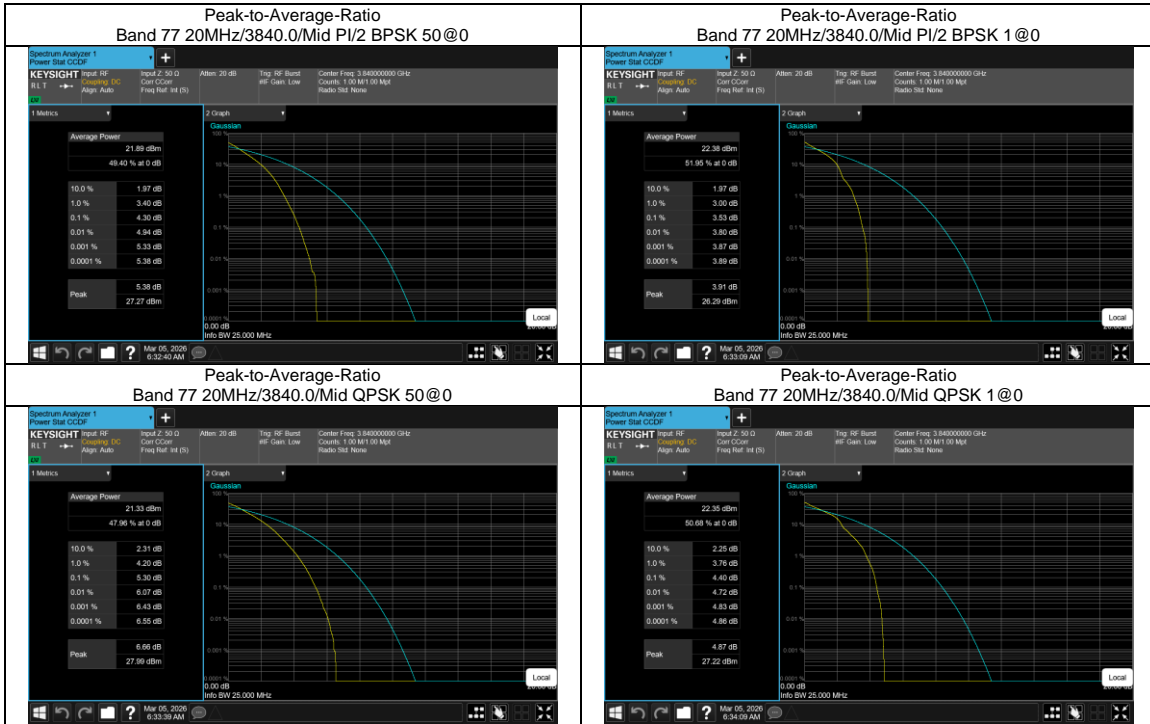



Occupied Bandwidth

Test Result

NR Band	SCS	BandWidth	Arfcn	Freq(MHz)	Modulation	RB	OBW(MHz)	26dB OBW(MHz)
77	30	10	656000	3840.0	CP-OFDM QPSK	24@0	8.59	9.456
77	30	10	656000	3840.0	CP-OFDM 16 QAM	24@0	8.6	9.266
77	30	15	656000	3840.0	CP-OFDM QPSK	38@0	13.58	14.75
77	30	15	656000	3840.0	CP-OFDM 16 QAM	38@0	13.62	14.56
77	30	20	656000	3840.0	CP-OFDM QPSK	51@0	18.25	19.53
77	30	20	656000	3840.0	CP-OFDM 16 QAM	51@0	18.19	19.35
77	30	25	656000	3840.0	CP-OFDM QPSK	65@0	23.08	24.37
77	30	25	656000	3840.0	CP-OFDM 16 QAM	65@0	23.12	24.31
77	30	30	656000	3840.0	CP-OFDM QPSK	78@0	27.87	28.82
77	30	30	656000	3840.0	CP-OFDM 16 QAM	78@0	27.87	29.13
77	30	40	656000	3840.0	CP-OFDM QPSK	106@0	37.96	39.41
77	30	40	656000	3840.0	CP-OFDM 16 QAM	106@0	37.92	39.25
77	30	50	656000	3840.0	CP-OFDM QPSK	133@0	47.32	48.99
77	30	50	656000	3840.0	CP-OFDM 16 QAM	133@0	47.49	49.07
77	30	60	656000	3840.0	CP-OFDM QPSK	162@0	57.66	59.56
77	30	60	656000	3840.0	CP-OFDM 16 QAM	162@0	57.73	59.67
77	30	70	656000	3840.0	CP-OFDM QPSK	189@0	67.56	70.74
77	30	70	656000	3840.0	CP-OFDM 16 QAM	189@0	67.72	69.73
77	30	80	656000	3840.0	CP-OFDM QPSK	217@0	77.34	79.82
77	30	80	656000	3840.0	CP-OFDM 16 QAM	217@0	77.37	79.83
77	30	90	656000	3840.0	CP-OFDM QPSK	245@0	87.3	90.01
77	30	90	656000	3840.0	CP-OFDM 16 QAM	245@0	87.29	89.94
77	30	100	656000	3840.0	CP-OFDM QPSK	273@0	96.99	100.2
77	30	100	656000	3840.0	CP-OFDM 16 QAM	273@0	97.24	100.2



Test Graphs

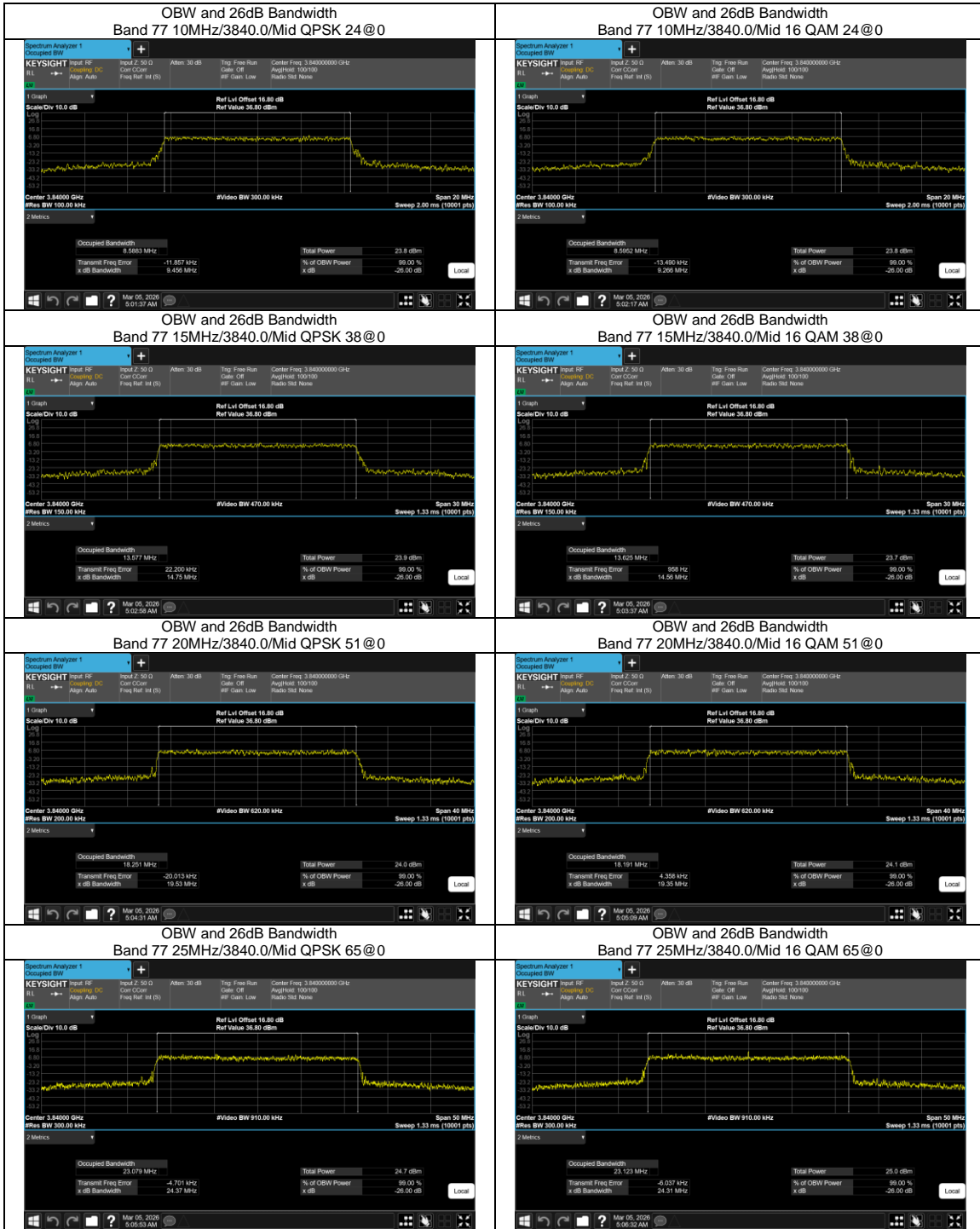

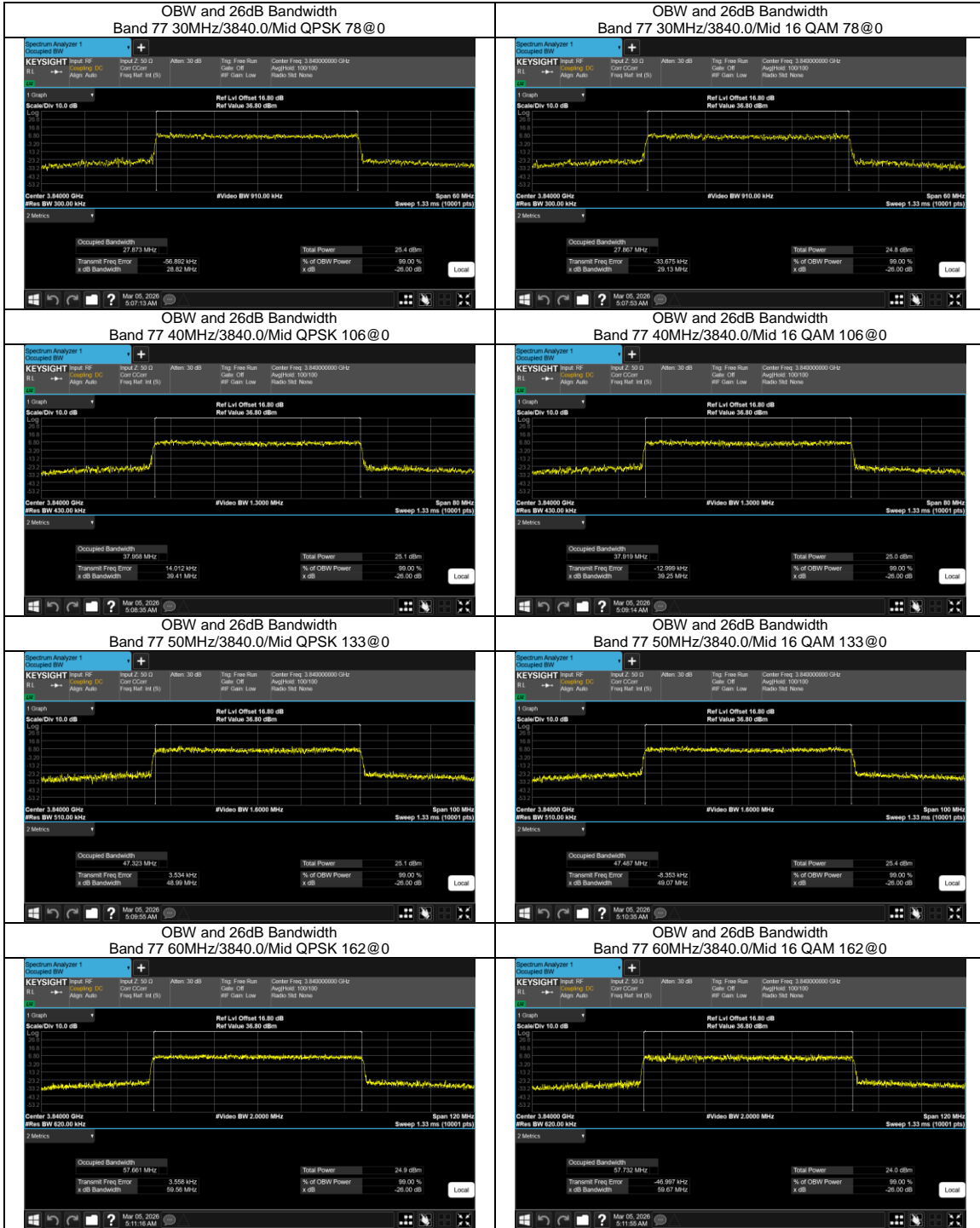

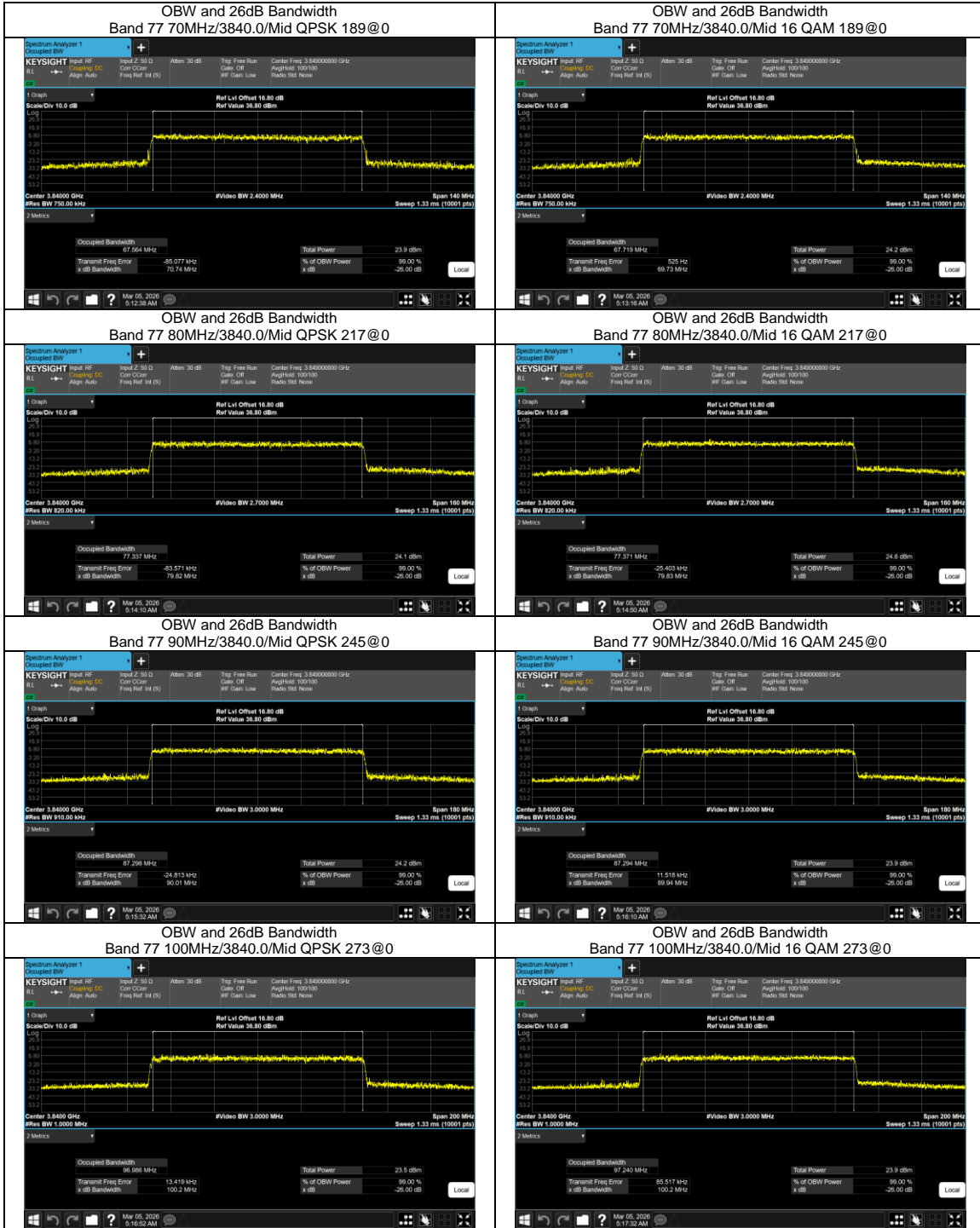



Conducted Spurious Emissions

Test Result

NR Band	SCS	BandWidth	Arfcn	Freq(MHz)	Modulation	RB	Freq_Range	Result	Limit	Verdict
77	30	10	647000	3705.0	DFT-s-OFDM BPSK	1@0	30.0MHz-20000MHz	21.481	-13	---
77	30	10	647000	3705.0	DFT-s-OFDM BPSK	1@0	20000MHz-39800.0MHz	-38.732	-13	PASS
77	30	10	656000	3840.0	DFT-s-OFDM BPSK	1@0	30.0MHz-20000MHz	21.09	-13	---
77	30	10	656000	3840.0	DFT-s-OFDM BPSK	1@0	20000MHz-39800.0MHz	-35.951	-13	PASS
77	30	10	665000	3975.0	DFT-s-OFDM BPSK	1@0	30.0MHz-20000MHz	20.76	-13	---
77	30	10	665000	3975.0	DFT-s-OFDM BPSK	1@0	20000MHz-39800.0MHz	-36.041	-13	PASS
77	30	50	648334	3725.01	DFT-s-OFDM BPSK	1@0	30.0MHz-20000MHz	20.908	-13	---
77	30	50	648334	3725.01	DFT-s-OFDM BPSK	1@0	20000MHz-39800.0MHz	-39.209	-13	PASS
77	30	50	656000	3840.0	DFT-s-OFDM BPSK	1@0	30.0MHz-20000MHz	21.023	-13	---
77	30	50	656000	3840.0	DFT-s-OFDM BPSK	1@0	20000MHz-39800.0MHz	-38.764	-13	PASS
77	30	50	663666	3954.99	DFT-s-OFDM BPSK	1@0	30.0MHz-20000MHz	20.029	-13	---
77	30	50	663666	3954.99	DFT-s-OFDM BPSK	1@0	20000MHz-39800.0MHz	-38.84	-13	PASS
77	30	100	650000	3750.0	DFT-s-OFDM BPSK	1@0	30.0MHz-20000MHz	21.256	-13	---
77	30	100	650000	3750.0	DFT-s-OFDM BPSK	1@0	20000MHz-39800.0MHz	-39.254	-13	PASS
77	30	100	656000	3840.0	DFT-s-OFDM BPSK	1@0	30.0MHz-20000MHz	19.214	-13	---
77	30	100	656000	3840.0	DFT-s-OFDM BPSK	1@0	20000MHz-39800.0MHz	-36.135	-13	PASS
77	30	100	662000	3930.0	DFT-s-OFDM BPSK	1@0	30.0MHz-20000MHz	21.865	-13	---
77	30	100	662000	3930.0	DFT-s-OFDM BPSK	1@0	20000MHz-39800.0MHz	-35.721	-13	PASS



Test Graphs

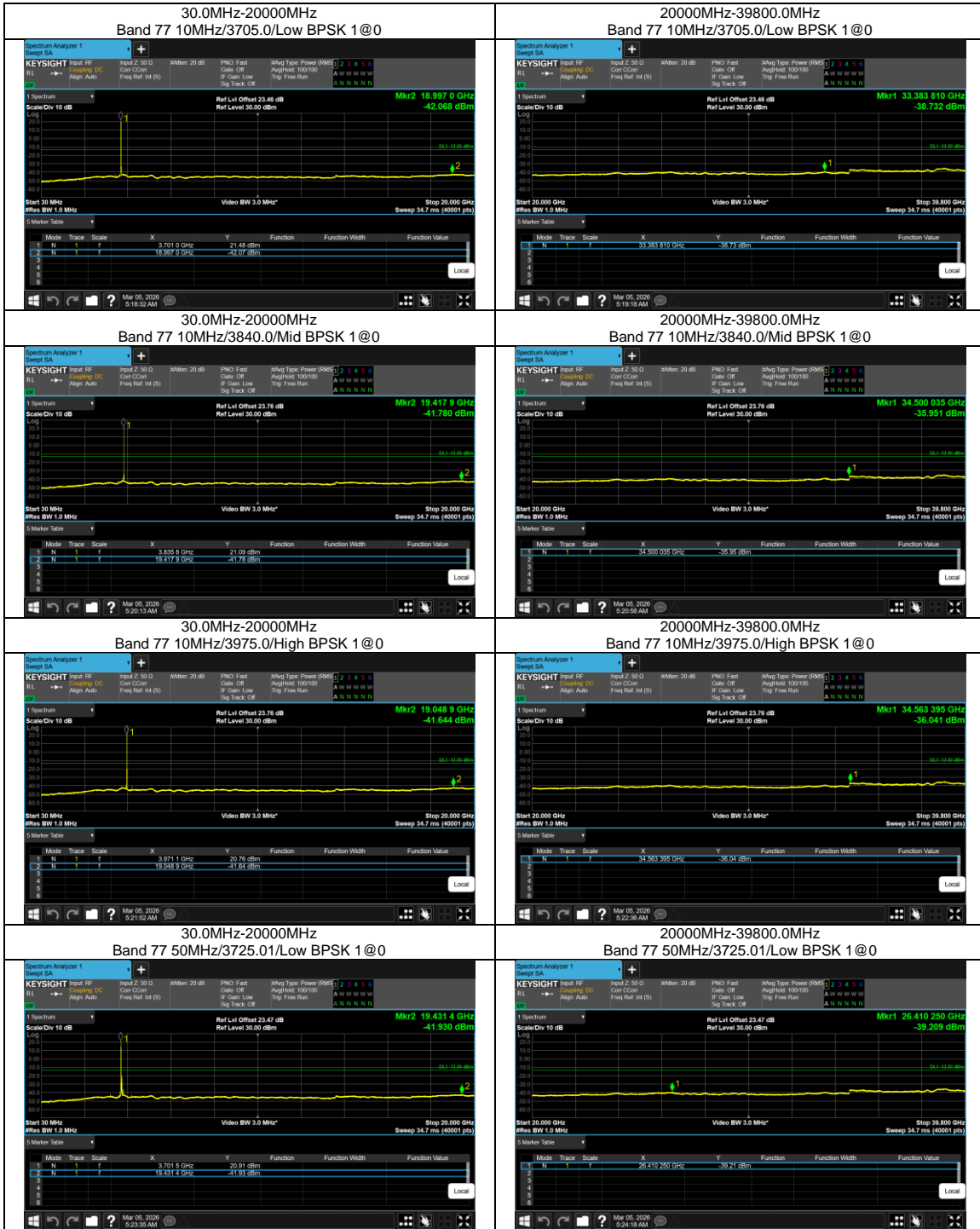

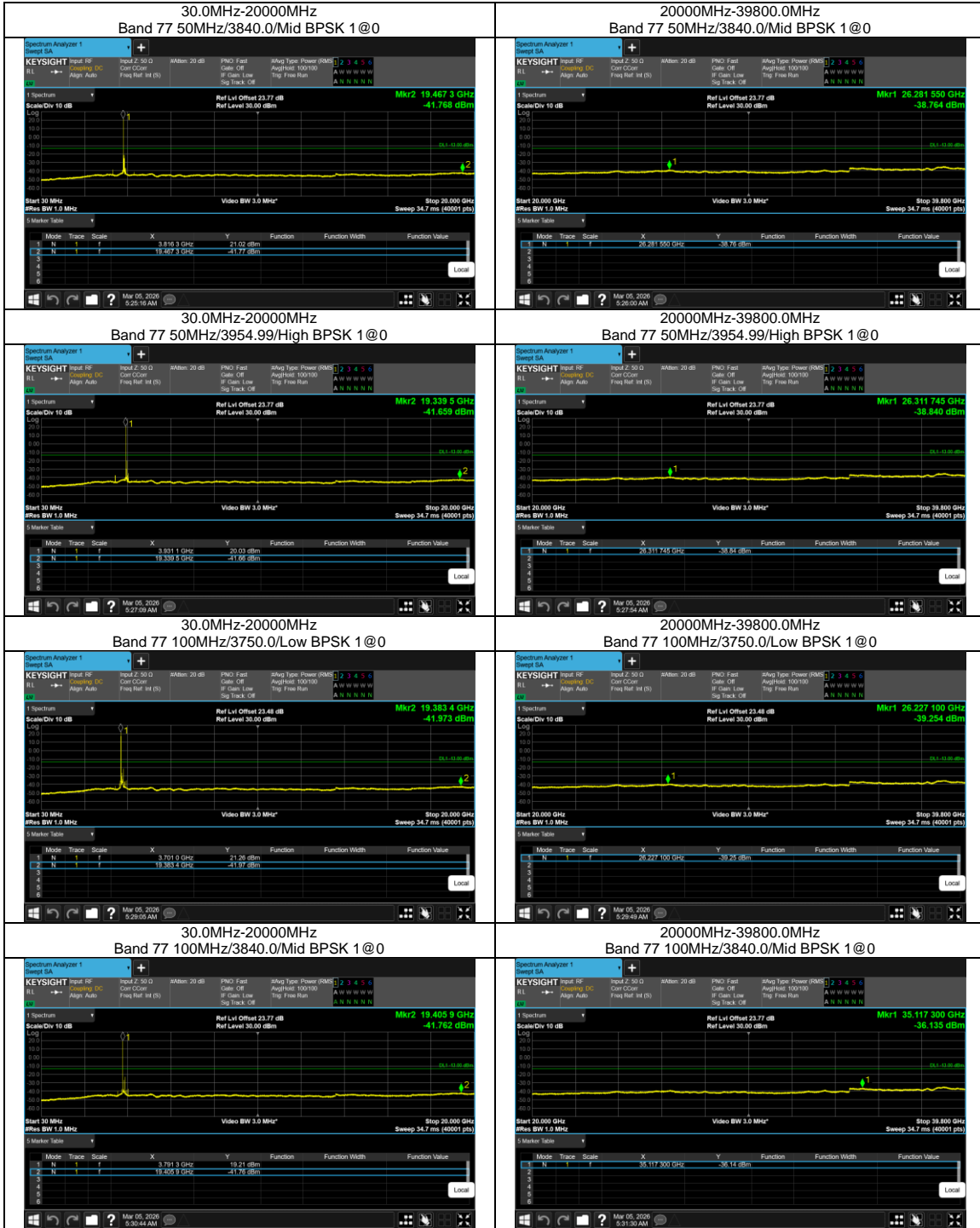

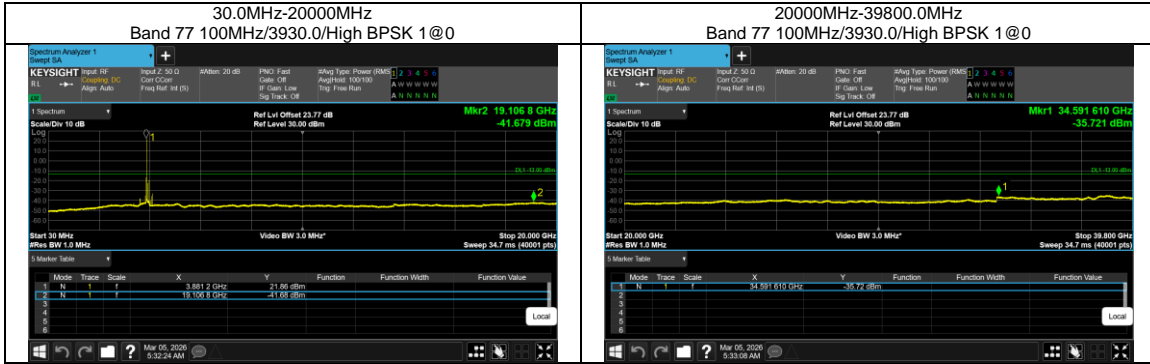



Conducted Band Edge

Test Result

NR Band	SCS	BandWidth	Arfcn	Freq(MHz)	Modulation	RB	Result	Verdict
77	30	10	647000	3705.0	DFT-s-OFDM BPSK	1@0	see graph	PASS
77	30	10	647000	3705.0	DFT-s-OFDM QPSK	1@0	see graph	PASS
77	30	10	647000	3705.0	DFT-s-OFDM BPSK	24@0	see graph	PASS
77	30	10	647000	3705.0	DFT-s-OFDM QPSK	24@0	see graph	PASS
77	30	10	665000	3975.0	DFT-s-OFDM BPSK	1@23	see graph	PASS
77	30	10	665000	3975.0	DFT-s-OFDM QPSK	1@23	see graph	PASS
77	30	10	665000	3975.0	DFT-s-OFDM BPSK	24@0	see graph	PASS
77	30	10	665000	3975.0	DFT-s-OFDM QPSK	24@0	see graph	PASS
77	30	50	648334	3725.01	DFT-s-OFDM BPSK	1@0	see graph	PASS
77	30	50	648334	3725.01	DFT-s-OFDM QPSK	1@0	see graph	PASS
77	30	50	648334	3725.01	DFT-s-OFDM BPSK	128@0	see graph	PASS
77	30	50	648334	3725.01	DFT-s-OFDM QPSK	128@0	see graph	PASS
77	30	50	663666	3954.99	DFT-s-OFDM BPSK	1@132	see graph	PASS
77	30	50	663666	3954.99	DFT-s-OFDM QPSK	1@132	see graph	PASS
77	30	50	663666	3954.99	DFT-s-OFDM BPSK	128@0	see graph	PASS
77	30	50	663666	3954.99	DFT-s-OFDM QPSK	128@0	see graph	PASS
77	30	100	650000	3750.0	DFT-s-OFDM BPSK	1@0	see graph	PASS
77	30	100	650000	3750.0	DFT-s-OFDM QPSK	1@0	see graph	PASS
77	30	100	650000	3750.0	DFT-s-OFDM BPSK	270@0	see graph	PASS
77	30	100	650000	3750.0	DFT-s-OFDM QPSK	270@0	see graph	PASS
77	30	100	662000	3930.0	DFT-s-OFDM BPSK	1@272	see graph	PASS
77	30	100	662000	3930.0	DFT-s-OFDM QPSK	1@272	see graph	PASS
77	30	100	662000	3930.0	DFT-s-OFDM BPSK	270@0	see graph	PASS
77	30	100	662000	3930.0	DFT-s-OFDM QPSK	270@0	see graph	PASS



Test Graphs

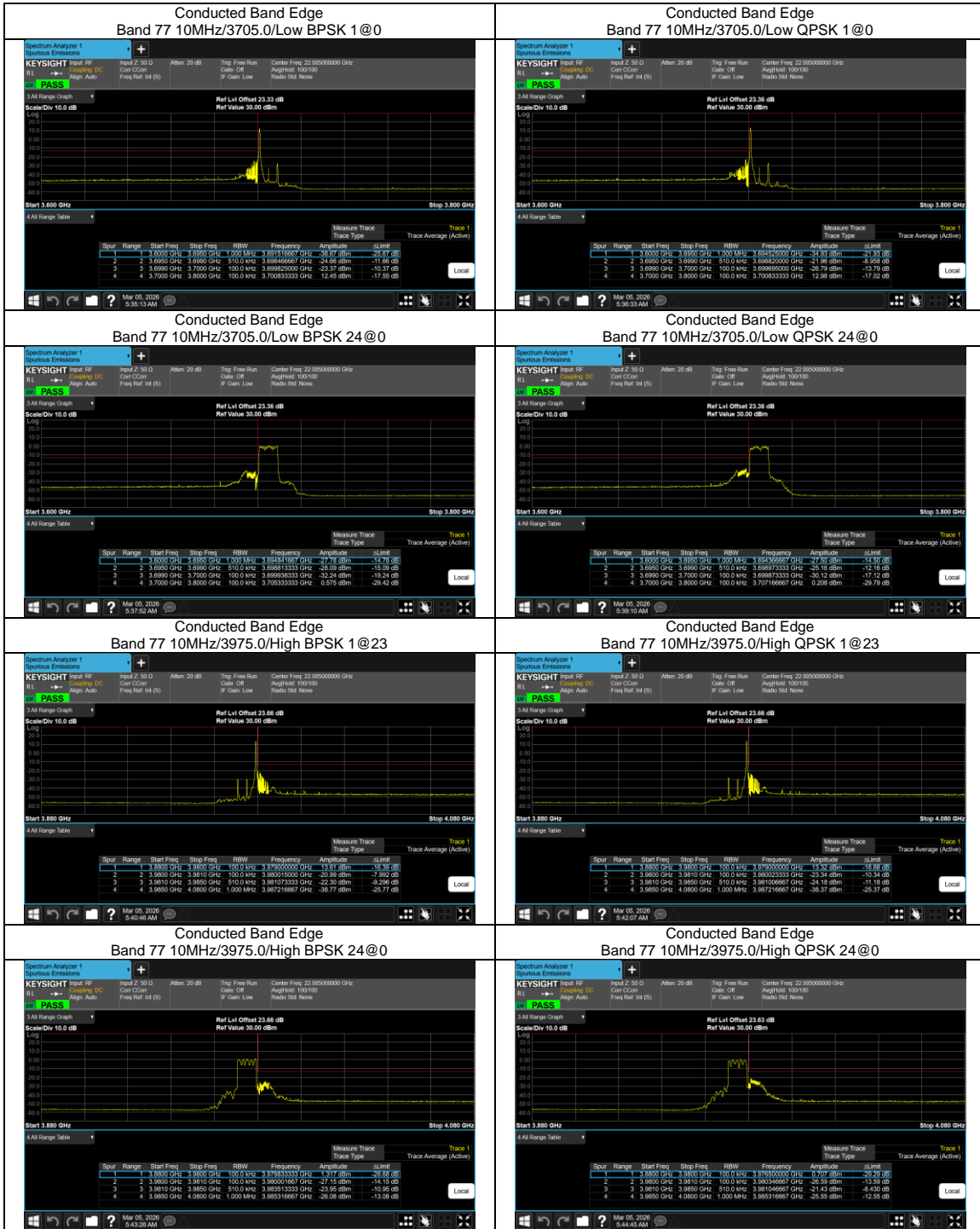

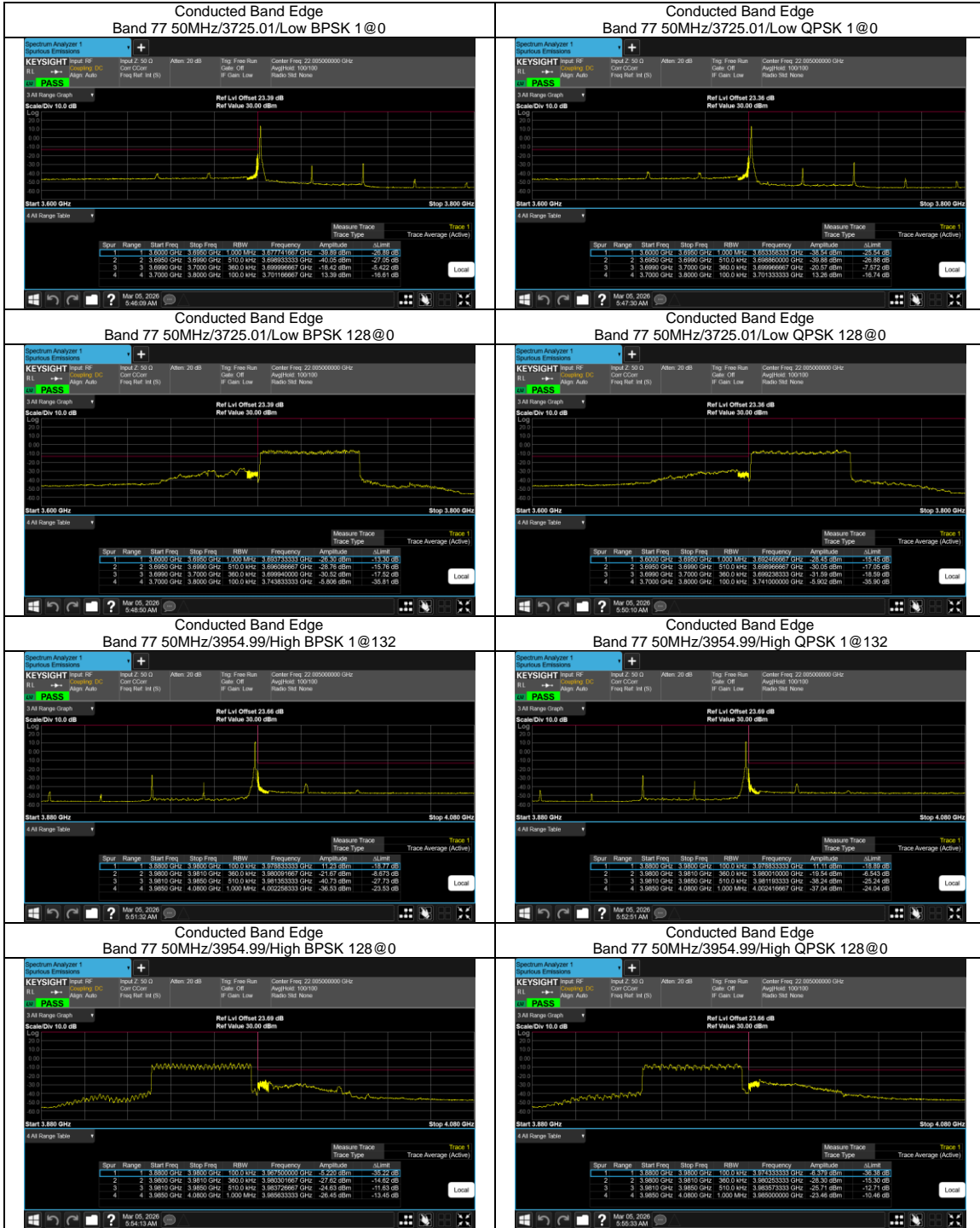

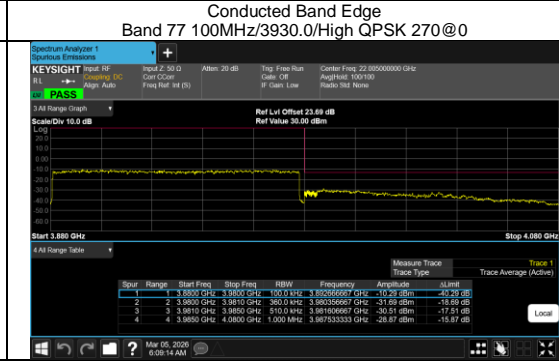
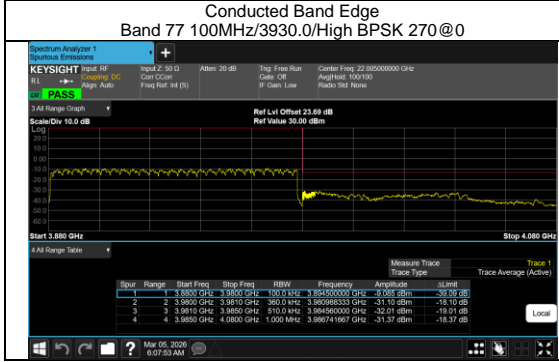
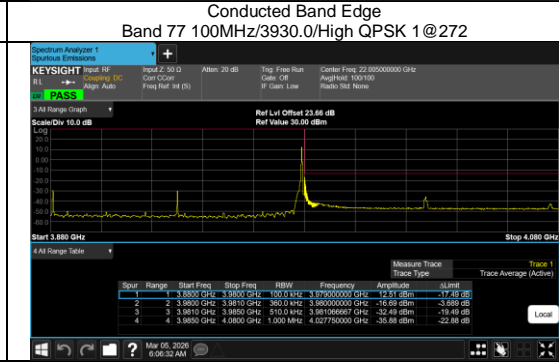
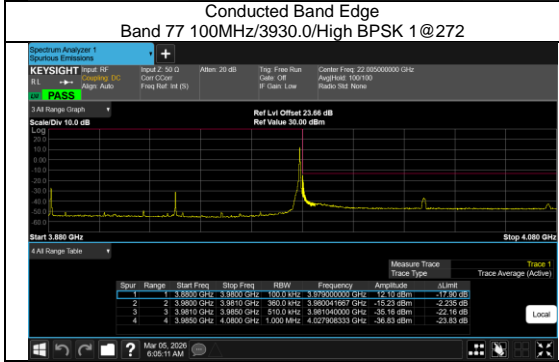
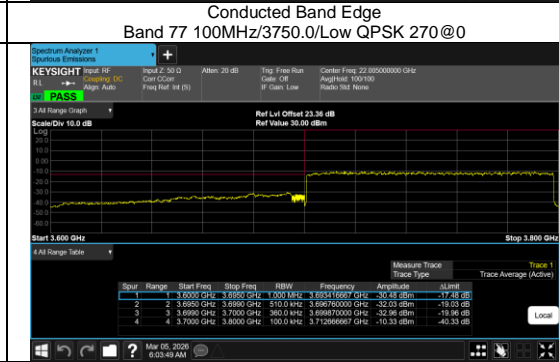
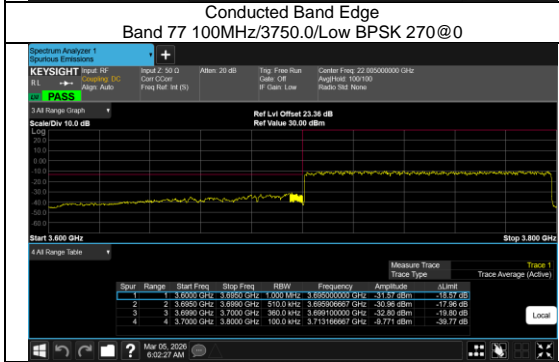
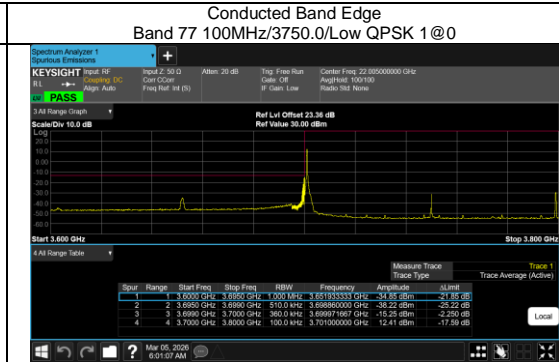
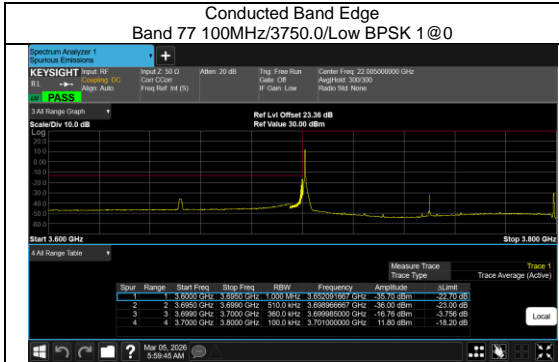



Software Version: 23.06.1602

FR1 N78_ANT4

Transmitter Conducted Output Power And EIRP, (G_T - L_c)= -3.0 dB

NR Band	SCS	BandWidth	Arfcn	Freq(MHz)	Modulation	RB	Conducted Power(dBm)	EIRP(dBm)	EIRP(W)
78	30	10	647000	3705	DFT-s-OFDM PI/2 BPSK	1@1	25.06	22.06	0.1607
78	30	10	647000	3705	DFT-s-OFDM QPSK	1@1	25.25	22.25	0.1679
78	30	10	647000	3705	DFT-s-OFDM 16 QAM	1@1	23.84	20.84	0.1213
78	30	10	650000	3750	DFT-s-OFDM PI/2 BPSK	1@1	25.43	22.43	0.1750
78	30	10	650000	3750	DFT-s-OFDM QPSK	1@1	25.57	22.57	0.1807
78	30	10	650000	3750	DFT-s-OFDM 16 QAM	1@1	24.49	21.49	0.1409
78	30	10	653000	3795	DFT-s-OFDM PI/2 BPSK	1@1	25.31	22.31	0.1702
78	30	10	653000	3795	DFT-s-OFDM QPSK	1@1	25.43	22.43	0.1750
78	30	10	653000	3795	DFT-s-OFDM 16 QAM	1@1	24.36	21.36	0.1368
78	30	15	647168	3707.52	DFT-s-OFDM PI/2 BPSK	1@1	25.01	22.01	0.1589
78	30	15	647168	3707.52	DFT-s-OFDM QPSK	1@1	25.24	22.24	0.1675
78	30	15	647168	3707.52	DFT-s-OFDM 16 QAM	1@1	23.71	20.71	0.1178
78	30	15	650000	3750	DFT-s-OFDM PI/2 BPSK	1@1	25.55	22.55	0.1799
78	30	15	650000	3750	DFT-s-OFDM QPSK	1@1	25.63	22.63	0.1832
78	30	15	650000	3750	DFT-s-OFDM 16 QAM	1@1	24.21	21.21	0.1321
78	30	15	652832	3792.48	DFT-s-OFDM PI/2 BPSK	1@1	25.21	22.21	0.1663
78	30	15	652832	3792.48	DFT-s-OFDM QPSK	1@1	25.34	22.34	0.1714
78	30	15	652832	3792.48	DFT-s-OFDM 16 QAM	1@1	23.88	20.88	0.1225
78	30	20	647334	3710.01	DFT-s-OFDM PI/2 BPSK	1@1	25.02	22.02	0.1592
78	30	20	647334	3710.01	DFT-s-OFDM QPSK	1@1	25.13	22.13	0.1633
78	30	20	647334	3710.01	DFT-s-OFDM 16 QAM	1@1	24.02	21.02	0.1265
78	30	20	650000	3750	DFT-s-OFDM PI/2 BPSK	1@1	25.53	22.53	0.1791
78	30	20	650000	3750	DFT-s-OFDM QPSK	1@1	25.69	22.69	0.1858
78	30	20	650000	3750	DFT-s-OFDM 16 QAM	1@1	24.04	21.04	0.1271
78	30	20	652666	3789.99	DFT-s-OFDM PI/2 BPSK	1@1	25.23	22.23	0.1671
78	30	20	652666	3789.99	DFT-s-OFDM QPSK	1@1	25.33	22.33	0.1710
78	30	20	652666	3789.99	DFT-s-OFDM 16 QAM	1@1	24.28	21.28	0.1343
78	30	25	647500	3712.5	DFT-s-OFDM PI/2 BPSK	1@1	25.06	22.06	0.1607
78	30	25	647500	3712.5	DFT-s-OFDM QPSK	1@1	25.10	22.10	0.1622
78	30	25	647500	3712.5	DFT-s-OFDM 16 QAM	1@1	24.12	21.12	0.1294



78	30	25	650000	3750	DFT-s-OFDM PI/2 BPSK	1@1	25.53	22.53	0.1791
78	30	25	650000	3750	DFT-s-OFDM QPSK	1@1	25.66	22.66	0.1845
78	30	25	650000	3750	DFT-s-OFDM 16 QAM	1@1	24.58	21.58	0.1439
78	30	25	652500	3787.5	DFT-s-OFDM PI/2 BPSK	1@1	25.31	22.31	0.1702
78	30	25	652500	3787.5	DFT-s-OFDM QPSK	1@1	25.46	22.46	0.1762
78	30	25	652500	3787.5	DFT-s-OFDM 16 QAM	1@1	23.99	20.99	0.1256
78	30	30	647668	3715.02	DFT-s-OFDM PI/2 BPSK	1@1	25.15	22.15	0.1641
78	30	30	647668	3715.02	DFT-s-OFDM QPSK	1@1	25.21	22.21	0.1663
78	30	30	647668	3715.02	DFT-s-OFDM 16 QAM	1@1	24.20	21.20	0.1318
78	30	30	650000	3750	DFT-s-OFDM PI/2 BPSK	1@1	25.58	22.58	0.1811
78	30	30	650000	3750	DFT-s-OFDM QPSK	1@1	25.68	22.68	0.1854
78	30	30	650000	3750	DFT-s-OFDM 16 QAM	1@1	24.71	21.71	0.1483
78	30	30	652332	3784.98	DFT-s-OFDM PI/2 BPSK	1@1	25.27	22.27	0.1687
78	30	30	652332	3784.98	DFT-s-OFDM QPSK	1@1	25.41	22.41	0.1742
78	30	30	652332	3784.98	DFT-s-OFDM 16 QAM	1@1	23.98	20.98	0.1253
78	30	40	648000	3720	DFT-s-OFDM PI/2 BPSK	1@1	25.06	22.06	0.1607
78	30	40	648000	3720	DFT-s-OFDM QPSK	1@1	25.10	22.10	0.1622
78	30	40	648000	3720	DFT-s-OFDM 16 QAM	1@1	23.96	20.96	0.1247
78	30	40	650000	3750	DFT-s-OFDM PI/2 BPSK	1@1	25.53	22.53	0.1791
78	30	40	650000	3750	DFT-s-OFDM QPSK	1@1	25.69	22.69	0.1858
78	30	40	650000	3750	DFT-s-OFDM 16 QAM	1@1	24.53	21.53	0.1422
78	30	40	652000	3780	DFT-s-OFDM PI/2 BPSK	1@1	25.33	22.33	0.1710
78	30	40	652000	3780	DFT-s-OFDM QPSK	1@1	25.41	22.41	0.1742
78	30	40	652000	3780	DFT-s-OFDM 16 QAM	1@1	24.33	21.33	0.1358
78	30	50	648334	3725.01	DFT-s-OFDM PI/2 BPSK	1@1	25.09	22.09	0.1618
78	30	50	648334	3725.01	DFT-s-OFDM QPSK	1@1	25.20	22.20	0.1660
78	30	50	648334	3725.01	DFT-s-OFDM 16 QAM	1@1	23.89	20.89	0.1227
78	30	50	650000	3750	DFT-s-OFDM PI/2 BPSK	1@1	25.55	22.55	0.1799
78	30	50	650000	3750	DFT-s-OFDM QPSK	1@1	25.69	22.69	0.1858
78	30	50	650000	3750	DFT-s-OFDM 16 QAM	1@1	24.28	21.28	0.1343
78	30	50	651666	3774.99	DFT-s-OFDM PI/2 BPSK	1@1	25.36	22.36	0.1722
78	30	50	651666	3774.99	DFT-s-OFDM QPSK	1@1	25.56	22.56	0.1803
78	30	50	651666	3774.99	DFT-s-OFDM 16 QAM	1@1	24.43	21.43	0.1390
78	30	60	648668	3730.02	DFT-s-OFDM PI/2 BPSK	1@1	25.13	22.13	0.1633
78	30	60	648668	3730.02	DFT-s-OFDM QPSK	1@1	25.35	22.35	0.1718
78	30	60	648668	3730.02	DFT-s-OFDM 16 QAM	1@1	23.82	20.82	0.1208



78	30	60	650000	3750	DFT-s-OFDM PI/2 BPSK	1@1	25.58	22.58	0.1811
78	30	60	650000	3750	DFT-s-OFDM QPSK	1@1	25.69	22.69	0.1858
78	30	60	650000	3750	DFT-s-OFDM 16 QAM	1@1	24.37	21.37	0.1371
78	30	60	651332	3769.98	DFT-s-OFDM PI/2 BPSK	1@1	25.63	22.63	0.1832
78	30	60	651332	3769.98	DFT-s-OFDM QPSK	1@1	25.76	22.76	0.1888
78	30	60	651332	3769.98	DFT-s-OFDM 16 QAM	1@1	24.17	21.17	0.1309
78	30	70	649000	3735	DFT-s-OFDM PI/2 BPSK	1@1	20.43	17.43	0.0553
78	30	70	649000	3735	DFT-s-OFDM QPSK	1@1	20.35	17.35	0.0543
78	30	70	649000	3735	DFT-s-OFDM 16 QAM	1@1	19.39	16.39	0.0436
78	30	70	650000	3750	DFT-s-OFDM PI/2 BPSK	1@1	21.45	18.45	0.0700
78	30	70	650000	3750	DFT-s-OFDM QPSK	1@1	21.36	18.36	0.0685
78	30	70	650000	3750	DFT-s-OFDM 16 QAM	1@1	20.61	17.61	0.0577
78	30	70	651000	3765	DFT-s-OFDM PI/2 BPSK	1@1	21.48	18.48	0.0705
78	30	70	651000	3765	DFT-s-OFDM QPSK	1@1	21.48	18.48	0.0705
78	30	70	651000	3765	DFT-s-OFDM 16 QAM	1@1	20.62	17.62	0.0578
78	30	80	649334	3740.01	DFT-s-OFDM PI/2 BPSK	1@1	25.15	22.15	0.1641
78	30	80	649334	3740.01	DFT-s-OFDM QPSK	1@1	25.22	22.22	0.1667
78	30	80	649334	3740.01	DFT-s-OFDM 16 QAM	1@1	24.07	21.07	0.1279
78	30	80	650000	3750	DFT-s-OFDM PI/2 BPSK	1@1	25.39	22.39	0.1734
78	30	80	650000	3750	DFT-s-OFDM QPSK	1@1	25.58	22.58	0.1811
78	30	80	650000	3750	DFT-s-OFDM 16 QAM	1@1	24.02	21.02	0.1265
78	30	80	650666	3759.99	DFT-s-OFDM PI/2 BPSK	1@1	25.70	22.70	0.1862
78	30	80	650666	3759.99	DFT-s-OFDM QPSK	1@1	25.67	22.67	0.1849
78	30	80	650666	3759.99	DFT-s-OFDM 16 QAM	1@1	24.92	21.92	0.1556
78	30	90	649668	3745.02	DFT-s-OFDM PI/2 BPSK	1@1	25.23	22.23	0.1671
78	30	90	649668	3745.02	DFT-s-OFDM QPSK	1@1	25.25	22.25	0.1679
78	30	90	649668	3745.02	DFT-s-OFDM 16 QAM	1@1	24.09	21.09	0.1285
78	30	90	650000	3750	DFT-s-OFDM PI/2 BPSK	1@1	25.33	22.33	0.1710
78	30	90	650000	3750	DFT-s-OFDM QPSK	1@1	25.42	22.42	0.1746
78	30	90	650000	3750	DFT-s-OFDM 16 QAM	1@1	24.03	21.03	0.1268
78	30	90	650332	3754.98	DFT-s-OFDM PI/2 BPSK	1@1	25.43	22.43	0.1750
78	30	90	650332	3754.98	DFT-s-OFDM QPSK	1@1	25.57	22.57	0.1807
78	30	90	650332	3754.98	DFT-s-OFDM 16 QAM	1@1	24.41	21.41	0.1384
78	30	100	650000	3750	DFT-s-OFDM PI/2 BPSK	1@1	25.18	22.18	0.1652
78	30	100	650000	3750	DFT-s-OFDM PI/2 BPSK	1@0	23.18	20.18	0.1042
78	30	100	650000	3750	DFT-s-OFDM PI/2 BPSK	1@271	25.40	22.40	0.1738



78	30	100	650000	3750	DFT-s-OFDM PI/2 BPSK	2@0	23.19	20.19	0.1045
78	30	100	650000	3750	DFT-s-OFDM PI/2 BPSK	135@67	25.40	22.40	0.1738
78	30	100	650000	3750	DFT-s-OFDM PI/2 BPSK	2@271	23.32	20.32	0.1076
78	30	100	650000	3750	DFT-s-OFDM PI/2 BPSK	270@0	23.40	20.40	0.1096
78	30	100	650000	3750	DFT-s-OFDM QPSK	1@1	25.26	22.26	0.1683
78	30	100	650000	3750	DFT-s-OFDM QPSK	1@0	23.24	20.24	0.1057
78	30	100	650000	3750	DFT-s-OFDM QPSK	1@271	25.48	22.48	0.1770
78	30	100	650000	3750	DFT-s-OFDM QPSK	2@0	23.08	20.08	0.1019
78	30	100	650000	3750	DFT-s-OFDM QPSK	135@67	25.44	22.44	0.1754
78	30	100	650000	3750	DFT-s-OFDM QPSK	2@271	23.27	20.27	0.1064
78	30	100	650000	3750	DFT-s-OFDM QPSK	270@0	23.06	20.06	0.1014
78	30	100	650000	3750	DFT-s-OFDM 16 QAM	1@1	24.06	21.06	0.1276
78	30	100	650000	3750	DFT-s-OFDM 64 QAM	1@1	23.47	20.47	0.1114
78	30	100	650000	3750	DFT-s-OFDM 256 QAM	1@1	21.16	18.16	0.0655
78	30	100	650000	3750	DFT-s-OFDM 16 QAM	270@0	22.11	19.11	0.0815
78	30	100	650000	3750	DFT-s-OFDM 64 QAM	270@0	21.60	18.60	0.0724
78	30	100	650000	3750	DFT-s-OFDM 256 QAM	270@0	18.64	15.64	0.0366
78	30	100	650000	3750	CP-OFDM QPSK	1@1	23.91	20.91	0.1233
78	30	100	650000	3750	CP-OFDM 16 QAM	1@1	23.87	20.87	0.1222



Appendix B. Test Results of Radiated Test

Radiated Spurious Emission

Test Engineer :	Simle Wang	Temperature :	22~23°C
		Relative Humidity :	40~42%

RSE pre-scanned harmonic for different antennas, choose the worst antenna perform final test and record in the report.

n77 SA / NR 100MHz / QPSK								
Channel	Frequency (MHz)	EIRP (dBm)	Limit (dBm)	Over Limit (dB)	S.G. Power (dBm)	TX Cable loss (dB)	TX Antenna Gain (dBi)	Polarization (H/V)
Middle	7584	-43.65	-13	-30.65	-53.86	3.03	13.24	H
	11376	-55.07	-13	-42.07	-64.52	3.56	13.01	H
	15168	-55.45	-13	-42.45	-64.97	3.92	13.44	H
	7584	-46.43	-13	-33.43	-56.64	3.03	13.24	V
	11376	-55.50	-13	-42.50	-64.95	3.56	13.01	V
	15168	-57.67	-13	-44.67	-67.19	3.92	13.44	V

Remark: Spurious emissions within 30-1000MHz were found more than 20dB below limit line.

n78 SA / NR 100MHz / QPSK								
Channel	Frequency (MHz)	EIRP (dBm)	Limit (dBm)	Over Limit (dB)	S.G. Power (dBm)	TX Cable loss (dB)	TX Antenna Gain (dBi)	Polarization (H/V)
Middle	7404	-36.15	-13	-23.15	-46.36	3.03	13.24	H
	11100	-49.63	-13	-36.63	-59.08	3.56	13.01	H
	14808	-51.68	-13	-38.68	-61.20	3.92	13.44	H
	7404	-37.10	-13	-24.10	-47.31	3.03	13.24	V
	11100	-54.78	-13	-41.78	-64.23	3.56	13.01	V
	14808	-49.12	-13	-36.12	-58.64	3.92	13.44	V

Remark: Spurious emissions within 30-1000MHz were found more than 20dB below limit line.